



AVENGER

REGULATED PCP AIR RIFLE

BULLPUP II

User Instruction Manual



PLEASE READ ALL INSTRUCTIONS AND WARNINGS
IN THIS MANUAL BEFORE USING.

PRE-CHARGED PNEUMATIC
PCP Air Rifle

CONTENTS

Rules of safe shooting	3
Warnings	4
Parts of your Avenger Bullpup II air rifle	5
Operating the safety	6
Pressurizing with compressed air	7
Depressurizing the air rifle	8
Using a single-shot tray	8
Loading the rotary magazine	9
Inserting the rotary magazine	9
Loading and shooting instructions	10
Automatic overpressure relief valve	10
Trigger adjustment.....	11
Hammer Spring (Velocity) Adjustment	12
Externally Adjustable Regulator.....	13
Maintenance	14
Warranty	15

RULES OF SAFE SHOOTING

- **NEVER** point the airgun at any person.
- **NEVER** point the airgun at anything you do not intend to shoot.
- **ALWAYS** treat the airgun as if it is loaded and handle it with the same respect you would a firearm.
- **ALWAYS** aim in a **SAFE DIRECTION**. **ALWAYS** keep the muzzle pointed in a **SAFE DIRECTION**.
- **NEVER** put any part of your hand over the muzzle.
- **ALWAYS** keep the airgun **ON "SAFE"** until you are ready to shoot in a **SAFE DIRECTION**.
- Check behind and beyond your target to be certain you have a safe backstop and that no person or property can be endangered.
- Place the backstop in a location that will be safe should the backstop fail.
- Replace the backstop if it becomes worn.
- **ALWAYS** be sure of your target and what lies beyond it in case you miss.
- **NEVER** shoot at hard surfaces, water or anything else that may cause a ricochet.
- This airgun may only be used where your local laws permit or at shooting ranges allowed by the law, and only if the ammunition does not travel further than the shooting area. Keep in mind the maximum range of the ammunition. **ALWAYS** abide by laws and regulations that apply to airguns.
- **ALWAYS** check to see if the airgun is **ON "SAFE"** and unloaded when getting it from another person or from storage.
- **ALWAYS** keep your finger off the trigger and away from the trigger guard until ready to shoot.
- You and others with you should **ALWAYS** wear safety shooting glasses to protect your eyes.
- If your reading or prescription glasses are not certified safety glasses, make sure you wear shooting glasses over your regular glasses.
- The shooter and everyone in the vicinity should wear hearing protection when shooting and filling guns with high pressure air.
- **NEVER** load your gun until you're ready to shoot and it's safe to do so.
- **ALWAYS** use the correct caliber ammunition that is suitable for the airgun. Use **ONLY** ammunition designed for this airgun.
- **NEVER** reuse ammunition.
- **ALWAYS** store the airgun with the safety **ON "SAFE"**, unloaded, uncocked, separated from the ammunition, out of the reach of children, and in a secure location to prevent unauthorized people from accessing it.
- **DO NOT** attempt to disassemble or tamper with the airgun.
- **DO NOT** store the airgun loaded.
- **ALWAYS** store this airgun in a safe location.
- **ALWAYS** store ammunition separately from the gun.
- **NEVER** leave the airgun loaded if it is out of your reach.
- **ALWAYS** unload the airgun before giving it to someone else.
- **ALWAYS** read and follow the manufacturer's manual and instructions.
- **NEVER** let a person who has not completely read this manual use this product.

ALWAYS FOLLOW THESE SAFETY WARNINGS

⚠ WARNING: NOT A TOY. THIS AIR RIFLE IS INTENDED FOR ADULT USE ONLY. MISUSE OR CARELESS USE MAY CAUSE SERIOUS INJURY OR DEATH. MAY BE DANGEROUS UP TO 1,000 YARDS (914 METERS).

⚠ WARNING: DO NOT BRANDISH OR DISPLAY THIS AIRGUN IN PUBLIC; IT MAY CONFUSE PEOPLE AND MAY BE A CRIME. POLICE AND OTHERS MAY THINK IT IS A FIREARM. DO NOT CHANGE THE COLORATION OR MARKINGS TO MAKE IT LOOK MORE LIKE A FIREARM. THAT IS DANGEROUS AND MAY BE A CRIME.

⚠ WARNING: THIS IS A HIGH POWERED AIRGUN INTENDED FOR USE BY THOSE 18 YEARS OF AGE OR OLDER. READ ALL INSTRUCTIONS BEFORE USING. BUYER AND USER HAVE THE DUTY TO OBEY ALL LAWS ABOUT THE USE AND OWNERSHIP OF THIS AIRGUN.

⚠ WARNING: BE SURE THE AIRGUN IS ALWAYS POINTED IN A SAFE DIRECTION. NEVER POINT THE AIRGUN AT ANYONE EVEN IF IT IS UNLOADED. ALWAYS ASSUME AND HANDLE THE AIRGUN AS IF IT WERE LOADED AND READY TO FIRE.

⚠ WARNING: THIS PRODUCT CAN EXPOSE YOU TO CHEMICALS INCLUDING LEAD, WHICH IS KNOWN TO THE STATE OF CALIFORNIA TO CAUSE CANCER AND BIRTH DEFECTS OR OTHER REPRODUCTIVE HARM. FOR MORE INFORMATION GO TO WWW.P65WARNINGS.CA.GOV.

⚠ WARNING: USE ONLY COMPRESSED AIR IN THIS RIFLE. DO NOT USE OTHER GASSES, INCLUDING OXYGEN, WHICH CAN CAUSE A FIRE OR EXPLOSION THAT MAY RESULT IN SERIOUS INJURIES OR DEATH.

⚠ WARNING: TREAT YOUR AIR RIFLE AS IF IT IS ALWAYS LOADED AND READY TO FIRE. ALWAYS KEEP THE MUZZLE POINTED IN A SAFE DIRECTION. BE AWARE OF RICOCHET. NEVER SHOOT AT HARD SURFACES OR INTO WATER.

⚠ WARNING: DO NOT DISASSEMBLE OR ALTER YOUR AIR RIFLE. REPAIR SHOULD ONLY BE DONE BY AN AUTHORIZED REPAIR DEPARTMENT. OTHERWISE YOU WILL VOID YOUR WARRANTY.

⚠ WARNING: THIS AIR GUN IS DESIGNED FOR USE AT PRESSURES BETWEEN 10MPa ~ 30MPa (100BAR ~ 300BAR / 1450PSI ~ 4350PSI). MAX PRESSURE OF INTERNAL AIR RESERVOIR IS 30MPa (300BAR / 4350PSI). DO NOT FILL PAST THE MAX PRESSURE.

⚠ IMPORTANT YOU AND OTHERS WITH YOU SHOULD ALWAYS WEAR SAFETY GLASSES TO PROTECT YOUR EYES. READ ALL INSTRUCTIONS BEFORE USING.



PARTS OF YOUR AVENGER BULLPUP II AIR RIFLE

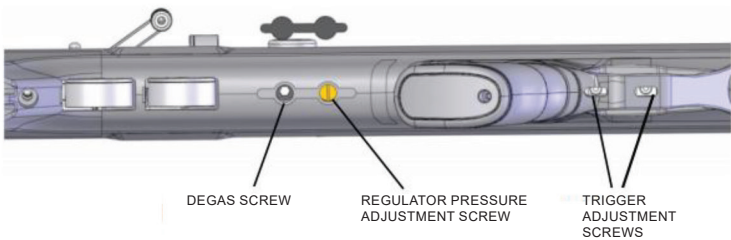
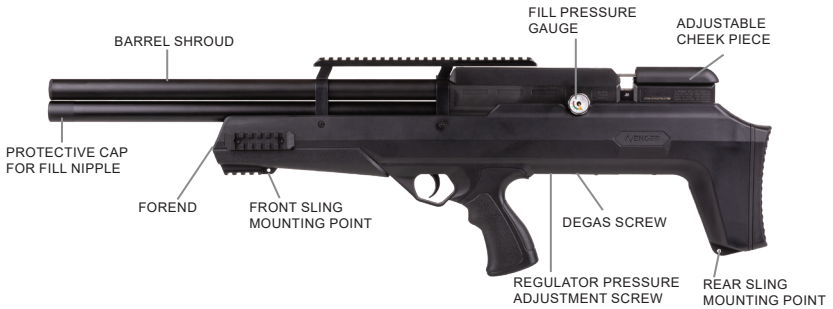

OPERATING THE SAFETY

- 1) The safety is located above the trigger. It allows you to set this air rifle to “S” (SAFE) and “F” (FIRE) positions.
- 2) Setting “S” (SAFE) Position: Pull rearward and the safety should point to the “S” indicator, and at the same time the safety should cover the red dot. (Fig. 2a)
- 3) Setting “F” (FIRE) Position: Push forward and the safety should point to the “F” indicator, and at the same time show the red dot signifying it is ready for shooting. (Fig. 2b)
- 4) The safety is only allowed to point at “S” or “F” position. Do not position in the middle of “S” and “F”. (Fig. 2c)

FIG. 2

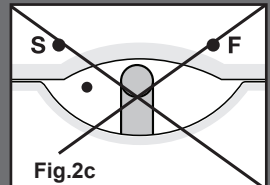
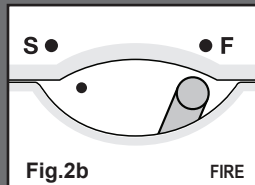
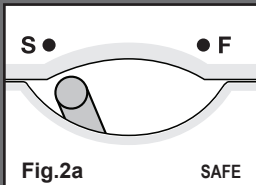

⚠ WARNING: LIKE ALL MECHANICAL DEVICES, AN AIR RIFLE SAFETY CAN FAIL. EVEN WHEN THE SAFETY IS SET TO “S” (SAFE) POSITION, CONTINUE HANDLING THE AIR RIFLE SAFELY. NEVER POINT THE AIR RIFLE AT ANY PERSON AND ANYTHING YOU DO NOT INTEND TO SHOOT.

PRESSURIZING (FILLING) WITH COMPRESSED AIR

- 1) Make sure the air rifle is unloaded, the Safety is on "S" (SAFE) position and keep the muzzle pointed in a safe direction. Be sure to wear eye protection.
- 2) Locate the protective cap on the reservoir and unscrew the cap (Fig.3a). You will see the male quick connector. (Fig.3b)
- 3) Connect the female quick connector from your fill device to the male quick connector (Fig.3C). Make sure the collar on the female fitting is in the forward, locked position. Check this by trying to pull the fitting off of the gun to make sure it is locked in.
- 4) When filling is completed, bleed the pressure in your fill device and disconnect the female quick connector from the male quick connector.
- 5) Screw on the protective cap to prevent oil and dirt from entering the male quick connector.

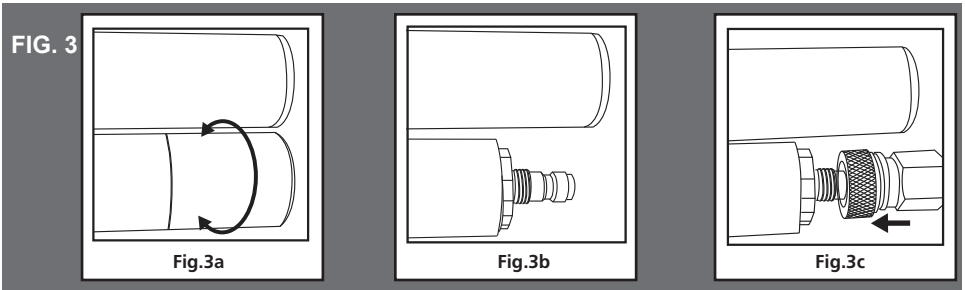

⚠ DANGER	
	DANGER OF EXPLOSION! Overfilled compressed air cylinder
Do NOT exceed the maximum fill pressure of 300 BAR (4,350 PSI) at room temperature!	

⚠ WARNING: THE AIR SHOULD BE PRESSURIZED SLOWLY. OTHERWISE, HEAT IS GENERATED THAT AFFECTS THE ACCURACY OF THE PRESSURE. OVERPRESSURE CAN CAUSE EXPLOSIONS, SERIOUS INJURIES OR DEATH.

⚠ WARNING: USE ONLY COMPRESSED AIR IN THIS RIFLE. DO NOT USE OTHER GASSES, INCLUDING OXYGEN, WHICH CAN CAUSE A FIRE OR EXPLOSION THAT MAY RESULT IN SERIOUS INJURIES OR DEATH.

⚠ WARNING: THIS AIR GUN IS DESIGNED FOR USE AT PRESSURES BETWEEN 10MPa ~ 30MPa (100BAR ~ 300BAR / 1450PSI ~ 4350PSI). MAX PRESSURE OF INTERNAL AIR RESERVOIR IS 30MPa (300BAR / 4350PSI). DO NOT FILL PAST THE MAX PRESSURE.

⚠ WARNING: BEFORE YOU DISCONNECT THE FEMALE QUICK CONNECTOR FROM THE RIFLE, THE FILL ASSEMBLY MUST BE DEPRESSURIZED SO THAT THERE IS NO AIR IN THE SYSTEM.

DEPRESSURIZING THE AIR RIFLE

1. Like most PCP air rifles, the Avenger is best stored with some pressure in the reservoir. This keeps the seals forced against the sealing surfaces.
2. Make sure the air rifle is unloaded, and the Safety is on "S" (SAFE) position. Keep the muzzle pointed in a safe direction. Be sure to wear eye protection.
3. Slowly turn the degassing screw counter-clockwise, using a 3mm Allen wrench. DO NOT rotate more than 2 revolutions. (Fig.4a)
4. DO NOT remove the degassing screw completely as the screw should remain with the stock.
5. After the rifle is depressurized, use a 3mm Allen wrench to tighten the degassing screw by turning clockwise.
6. Check the pressure gauge to make certain all pressure has been released from this air rifle.

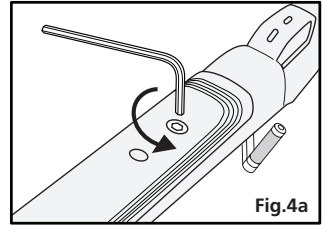

⚠ WARNING: PERFORMING THE ABOVE PROCEDURE MAY EXHAUST AIR FROM THE BARREL AT A HIGH RATE AND COULD DISCHARGE A PELLET THAT IS CHAMBERED. ALWAYS MAKE CERTAIN THIS AIR RIFLE IS POINTED AT A SAFE DIRECTION.

THE USE OF SINGLE PELLET TRAY

- Make sure the Safety is on "S" (SAFE) position and keep the muzzle pointed in a safe direction.
- Pull the bolt back to the cocked position.
- Insert the single pellet tray into the receiver. (Fig. 6a)
- Push and pull the bolt and make sure the receiver locking pin moves forward and backward freely.
- Lay a pellet of appropriate caliber in the pellet tray. (Fig. 6b)
- Push the bolt forward as far as possible. This chambers a pellet into the barrel and the air rifle is ready to fire. Be careful not to squeeze or damage the pellet as this could affect accuracy.

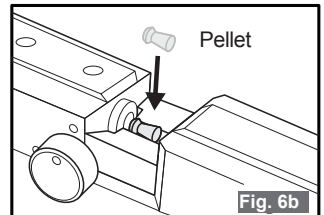
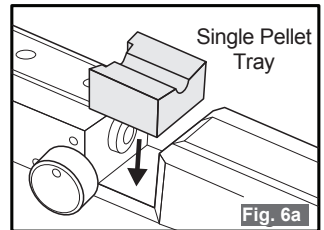

⚠ IMPORTANT DO NOT LOAD MORE THAN ONE PELLET INTO THE CHAMBER, IT MAY CAUSE DAMAGE AND MAY NOT FIRE.

LOADING THE ROTARY MAGAZINE

- Lift the transparent cover and turn clockwise along the direction of the arrow until it stops. (Fig. 7a, Fig. 7b)
- Place a finger under the magazine covering the hole.
- Place the first pellet in the magazine head first. Make certain the pellet does not protrude out the back of the magazine. In the event the pellet does protrude simply push the pellet inward. Be careful not to squeeze or damage the pellet as this could affect accuracy. (Fig. 7c)
- Rotate the cover counter-clockwise and place the remaining pellets into the magazine. Once full, lock the cover at the starting position and the magazine is now ready for use. (Fig. 7d)

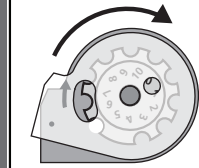

Fig. 7a

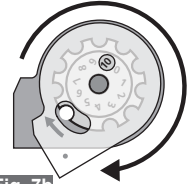

Fig. 7b

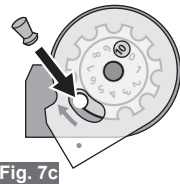

Fig. 7c

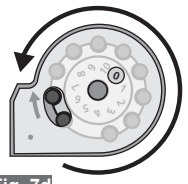

Fig. 7d

INSERTING THE ROTARY MAGAZINE

- 1) Make sure the Safety is on "S" (SAFE) position and keep the muzzle pointed in a safe direction.
- 2) Pull the bolt back to the cocked position.
- 3) With the transparent cover of the magazine facing to the back of the air rifle, insert the magazine from the right side and push it left until it snaps into place. (Fig. 8a)
- 4) Push the bolt forward until it stops, to chamber a pellet.
- 5) This air rifle is now ready to fire.
- 6) Only one pellet should be pushed into the chamber each time.
- 7) Do not repeat until you have fired the loaded pellet, this prevents more than one pellet feeding into the chamber.
- 8) This magazine is designed to stop automatically when empty. Pull the bolt back, and push the magazine out of the receiver from the left side. (Fig. 8b)
- 9) If you are done shooting and the magazine still has pellets in it, remove the magazine by pulling the side lever to the cocked position, and push the magazine out of the receiver from the left side.

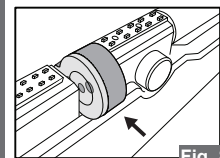

Fig. 8a

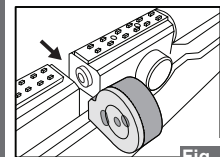

Fig. 8b

LOADING AND SHOOTING INSTRUCTIONS

- 1) Make sure the safety is on "S" (SAFE) position and keep the muzzle pointed in a safe direction.
- 2) Make sure the reservoir is filled with sufficient air.
- 3) Pull the side-lever action back to the cocked position.
- 4) Place the single pellet tray or rotary magazine into the receiver, and make sure it is installed correctly.
- 5) Push the side-lever action forward fully to the closed position to chamber a pellet.
- 6) Push the safety to point to "F" (FIRE).
- 7) Aim at target, pull the trigger and shoot.
- 8) Repeat steps above in reverse manner when not in use.
- 9) When you are finished shooting, make sure there are no pellets remaining in the chamber.

AUTOMATIC OVERPRESSURE RELIEF VALVE

- 1) This air rifle is equipped with an automatic overpressure relief valve. It protects the other parts of the air rifle from damage.
- 2) If damaged or it loses function, please contact Air Venturi for replacement at:
216-220-1180.

TRIGGER ADJUSTMENT

! IMPORTANT THIS AIR RIFLE IS FOR ADULTS. THE TRIGGER HAS BEEN FACTORY SET TO A SETTING THAT WILL SUIT MOST HUNTING AND TARGET USES. THEREFORE, ADVANCE CALIBRATION IS NOT REQUIRED.

! WARNING: ADJUSTMENT OF THE TRIGGER SCREWS COULD INHIBIT PROPER FUNCTION OF THE SAFETY. IT MAY CAUSE THE SAFETY TO NOT POINT AT "S" OR "F" POSITION. ALWAYS CHECK FOR FULL ENGAGEMENT AND SMOOTH FUNCTION OF THE SAFETY UPON COMPLETION OF ANY CHANGES TO THE ADJUSTMENT SCREWS.

! WARNING: ADJUSTMENT TO THE TRIGGER ASSEMBLY COULD ALLOW THIS AIR RIFLE TO FIRE IF DROPPED OR JARRED EVEN WITH OR WITHOUT THE SAFETY ENGAGED. THIS CAN CAUSE SERIOUS INJURIES OR DEATH.

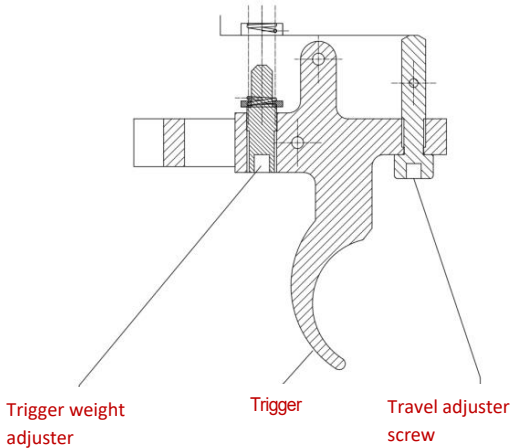

- 1) Before making any adjustments to the trigger, make sure the rifle is unloaded and that the rifle is not cocked. Always keep the rifle pointed in a safe direction.
- 2) **Trigger Weight Adjuster:** Use a 2.5mm Allen wrench and turn the adjuster screw clockwise to increase trigger pull weight and counter-clockwise to decrease trigger pull weight.
- 3) **Travel Adjuster:** Use a 2.5mm Allen wrench and turn the adjuster screw clockwise to reduce the amount of travel, this will move the trigger back. Turning counter-clockwise will increase the amount of travel and move the trigger forward.

HAMMER SPRING (VELOCITY) ADJUSTMENT

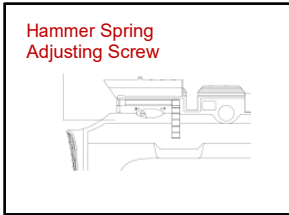
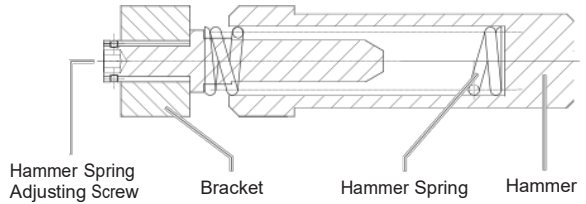

Fig. 13



- 1) Image (Fig. 13) explains where the hammer spring adjusting screw is located.
- 2) Use a 2.5mm Allen wrench to tune the Hammer Spring Adjusting Screw.
- 3) To increase velocity and tension of the hammer spring, rotate the Hammer Spring Adjusting Screw clockwise. To decrease velocity and hammer spring tension, rotate the Hammer Spring Adjusting Screw counter-clockwise.
- 4) After approximately 3,000 shots, the hammer spring adjustment screw may need to be turned clockwise one full turn to maintain factory velocity. One turn equals approx. 100fps.

EXTERNALLY ADJUSTABLE REGULATOR

To reduce the regulator pressure:

- 1) Move the safety to the "S" (SAFE) position and keep the muzzle pointed in a safe direction.
- 2) Depressurize the rifle following the procedure outlined on page 8.
- 3) Once the rifle is empty, locate the regulator adjustment screw on the underside of the air rifle.
- 4) Using a flathead screwdriver, rotate the adjustment screw clockwise until it stops (Fig. 9a), then rotate one quarter turn counter-clockwise (Fig. 9b). This will reset the regulator to a minimum setting.
- 5) Fill the rifle to 300 BAR / 4,350 PSI, following the procedure on page 7.
- 6) Using a flathead screwdriver, slowly rotate the adjustment screw counter-clockwise (Fig. 9b), at the same time, observe the regulator gauge. The pressure will gradually increase. Adjust to your ideal pressure.
- 7) To achieve best results, it is recommended that you adjust your hammer spring tension in conjunction with regulator adjustments.

⚠ WARNING: DO NOT ROTATE THE REGULATOR ADJUSTMENT SCREW CLOCKWISE WHILE THE RIFLE HAS PRESSURE IN IT. THIS CAN DAMAGE YOUR REGULATOR.

To increase the regulator pressure:

- 1) Move the safety to the "S" (SAFE) position and keep the muzzle pointed in a safe direction.
- 2) Fill the rifle to 300 BAR / 4,350 PSI, following the procedure on page 7.
- 3) Locate the regulator adjustment screw on the underside of the air rifle.
- 4) Using a flathead screwdriver, slowly rotate the adjustment screw counter-clockwise (Fig. 9b), at the same time, observe the regulator gauge. The pressure will gradually increase. Adjust to your ideal pressure.

⚠ WARNING: NEVER ADJUST THE REGULATOR PRESSURE ABOVE 3000 PSI / 210 BAR. THIS CAN DAMAGE THE REGULATOR.

- 5) To achieve best results, it is recommended that you adjust your hammer spring tension in conjunction with regulator adjustments.

⚠ WARNING: DO NOT ROTATE THE REGULATOR ADJUSTMENT SCREW CLOCKWISE WHILE THE RIFLE HAS PRESSURE IN IT. THIS CAN DAMAGE YOUR REGULATOR.

The Adjustment Reference Chart can be used to restore your rifle to a normal setting.

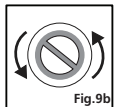
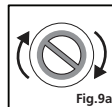

CALIBER	REGULATOR PRESSURE	SPRING ADJUSTMENT TURNS	VELOCITY ADJUSTMENT
.177 (4.5 MM)	ABOUT 140 BAR/2,000 PSI	ABOUT 3 TURNS	ABOUT 1,000 FPS
.22 (5.5 MM)	ABOUT 180 BAR/2,600 PSI	ABOUT 3 TURNS	ABOUT 950 FPS
.25 (6.35 MM)	ABOUT 200 BAR/2,900 PSI	ABOUT 3 TURNS	ABOUT 900 FPS

MAINTENANCE

- 1) Apply silicone lubricant to the breech o-ring on the bolt probe every 3 months or every 500 shots.
- 2) Apply a thin layer of Moly paste to the bolt probe every 3 months.
- 3) Always store with pressure (at least 1,000 PSI/69 BAR) in the air rifle. Store in a place that is free from moisture. Keep out of high humidity.

⚠ WARNING: DO NOT INTRODUCE PETROLEUM-BASED LUBRICANTS INTO THE HIGH-PRESSURED RESERVOIR, IT MAY CAUSE AN EXPLOSION. FAILURE TO FOLLOW THESE INSTRUCTIONS MAY RESULT IN SERIOUS INJURIES OR DEATH.

⚠ WARNING: DO NOT ATTEMPT TO DISASSEMBLE OR REPAIR THIS AIR RIFLE WHILE IT IS FILLED WITH AIR PRESSURE. PARTS CAN FLY FROM THIS AIR RIFLE AT DANGEROUS SPEEDS AND MAY CAUSE SERIOUS INJURIES OR DEATH.

WARRANTY

One-Year Limited Warranty

This product is warranted to the retail consumer for one year from date of retail purchase against defects in material and workmanship. In the unlikely event there are any defects in materials or workmanship in the first twelve (12) months after retail purchase, we will repair or replace the defective items under warranty.

What is covered:

Replacement parts and labor. Transportation charges to consumer for repaired product.

What is NOT covered:

- Transportation charges to Air Venturi for defective products.
- Any damage or faults caused by owner misuse, action or inaction.
- Damages caused by abuse or failure to perform normal maintenance.
- Any other expense.
- Parts subject to normal wear and tear.
- Consequential damages, incidental damages or incidental expenses including damage to property.

This warranty is in addition to your statutory rights. Retain your sales receipt as proof of purchase.

NOTE: *Some states do not allow the exclusion or limitation of incidental or consequential damages, so the above limitation or exclusion may not apply to you.*

Warranty claims:

Call Air Venturi at **216-220-1180** before returning any product.

Implied warranties:

Any implied warranties, including the implied warranties of merchantability and fitness for a particular purpose, are limited in duration to one year from date of retail purchase.

NOTE: *Some states do not allow limitations on how long an implied warranty lasts, so the above limitation may not apply to you.*

To the extent any provision of this warranty is prohibited by federal, state or municipal law which cannot be preempted, it shall not be applicable. This warranty gives you specific legal rights, and you may also have other rights which vary from state to state and country to country. Illustrations and photographs are for information purposes only and may not show the exact model purchased.

The warranty shall be invalid if the Airgun:

- Has been incorrectly disassembled, reassembled or maintained.
- Has been fitted with non-Air Venturi parts.
- Has been abused, misused or improperly stored.
- Original purchase receipt cannot be presented.



AIR VENTURI®

5135 Naiman Parkway, Cleveland, OH 44139

Ph: 216-292-2570 • fax: 216-373-0086