



This manual contains operating instructions and maintenance schedules for the high pressure breathing air compressors. Operators must read and understand all information inside the manual.

ATTENTION. This machine can be used only after a careful reading of this instruction manual. The machine may only be used to produce compressed air. Other use is strictly prohibited. The manufacturer and the supplier void all responsibility for damage or injury resulting from failure to follow these instructions.

1. GENERAL INFORMATION:

Before using the machine please put your attention to this general information:

1. Personnel engaged to operate the machine must have read the instruction manual before beginning work, especially the safety notices chapter.
2. Personnel may not wear long hair loose, loose clothing or jewellery, including rings.
3. Keep all safety and danger notices on the unit complete and in readable condition.
4. No modifications may be made to the unit which could impair safety without first obtaining permission from the suppliers.

5. Piping must be thoroughly checked (pressure and visual inspection) by the operator at appropriate time intervals, even if no safety related faults have been noticed.

6. Intervals stipulated or given in the instruction manual for recurring checks/inspections must be adhered to.

7. It is absolutely essential that the workplace is appropriately equipped for maintenance measures.

8. Work on/with the unit may only be carried out by reliable personnel. Observe the legal minimum age permissible.

2. PRESENTAZIONE GENERALE:

The ATLANTIC 100 high pressure compressors are designed to compress air for breathing as required in diving and fire fighting applications. The max pressure is 225 bar or 330 bar depending on unit.

The compressor unit comprises the following major assemblies:

Il compressore è composto da:

- . Compressor block
- . Electric or petrol/diesel engine
- . Filters

- . Filling assembly
- . Protection and anti-vibration frame
- . Automatic condensate drain*
- . Electric control system**
- . Automatic switch on/off*
- . ALLUMINUM frame

(*), (***) Optional extra according to order

3. GRUPPO COMPRESSORE

The compressor block ATLANTIC 100 is used to compress air in the high pressure range up to 330 bar (4500 psi). The compressor block is of a four stage, four cylinders design. The cylinders are arranged in the 1st stage on the left, 2nd stage on the right, 3rd and 4th stage on the centre side looking from the filter side. The compressor blocks are particularly suitable for continuous operation because of their rugged design and the corrosion resistant intermediate filter and cooler assemblies. Smooth running is a particular feature of this Nardi design. The moving parts of the driving gear are all equally balanced. This results in a vibration-free running. The driving gear is fitted with energy saving cylinder roller bearings. The upper and lower connecting rod bearings are also roller bearings. Crankcase, cylinders and heads are obtained from the gravity dies. Connecting rod are extracted from casting dies. Cylinder are in cast iron inside an aluminium pipe.



Description

1. Intake Filter
2. 1st stage
3. Inter-cooler 1st stage
4. 2nd stage
5. Inter-cooler 2nd stage
6. 3rd stage
7. Inter-cooler 3rd stage
8. 4th stage
9. Inter-cooler 4th stage
10. Oil indicator

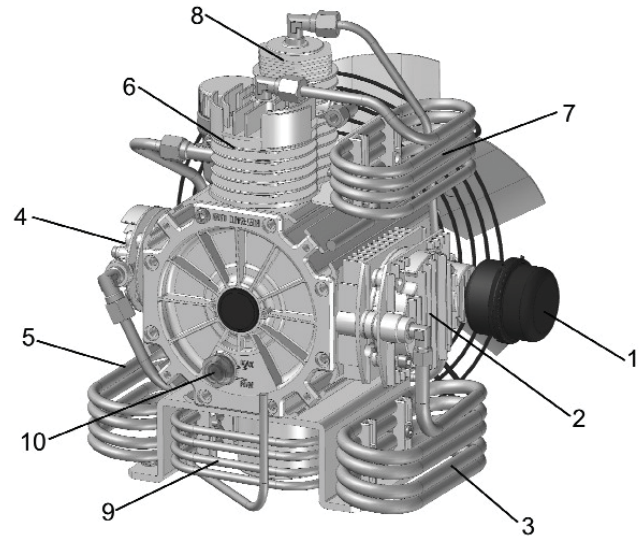

4. TECHNICAL DATA

Compressor unit	ATLANTIC 100	
Operating pressure	PN 200	PN300
Delivery *	100 L/min.	100 L/min.
Final pressure safety valve	225 Bar	330 Bar
Compressor block	ATLANTIC 100	
Number of stages	4	
Number of piston	4	
Cylinder bore stage 1	60 mm	
Cylinder bore stage 2	38 mm	
Cylinder bore stage 3	19 mm	
Cylinder bore stage 4	9,5 mm	
Piston stroke	23 mm	
Intermediate pressure stage 1	2,5 Bar	
Intermediate pressure stage 2	15 Bar	
Intermediate pressure stage 3	55 - 65 Bar	
Intermediate pressure stage 4	225 - 330 Bar	
Oil capacity	0,350 L.	
Oil Type	SHELL CORENA P150	
Max permissible ambient temp.	-5°C Min. +45°C Max. (+25°F Min. +113°F Max.)	
Max permissible inclination of compressor	20°	
Max dampness	80%	
Max sea level	2000 m sea level	
Weight	25 Kg.	
Drive engine	Mono phase	Three phase
Type engine	110-240 Volt / 50-60 Hz	230-400 Volt / 50-60 Hz
Power	3,0 Hp 2poli	
Speed	2850 r.p.m.	
Type of enclosure	IP 55	
Current rating	16,5 A (240 Volt) - ___ A (110 Volt)	
Petrol engine	ROBIN EX17 6,0 Hp 4 Stroke	
Switch on/off	MANUAL	
Cubic capacity	169 ml.	
Power	2,9 Kw-4,00 HP / 3600 r.p.m.	

5. SAFETY MEASURES

5.1. Fundamental safety notices:

Important instructions concerning the endangerment of personnel, technical safety and operating safety will be specially emphasized by special marks placing on the machine.

For safety reasons you can find some components mounted on the compressors in order to prevent damages. These parts must not be changed or removed in any case. Before please consult our technician.

5.2. Authorized use :

The unit is built according to state of the art technology and established safety technical regulations. Nevertheless, its use can cause danger to life and limb of the operator or third parties or damage to the machine and other equipment. Operate the unit only in technically perfect condition in accordance with regulations and safety danger notices detailed in the instruction manual. The manufacturer/supplier is not responsible for damage resulting from a wrong utilisation of the machine. The user alone is responsible for this risk. The compressor is built to produce top quality breathing air according to DIN EN 12021 rules.

5.3. Safety notices for operation :

- Ensure that only trained personnel work with the machine.
- Filling hoses must be in satisfactory condition and threads undamaged.
- Ensure intake air is free from noxious gas, exhaust fumes and solvent vapour.
- The use of petrol and diesel compressors is forbidden in indoor place.
- Check the unit externally for damage and faults periodically. Inform the department/person responsible immediately if anything is not as is should be (including operation). If necessary, shut the machine down immediately and make it safe. Observe switching on and off processes and monitoring indications according to the instructions manual.
- Use only Nardi original parts and equipments.
- Drain the valve regularly if manual drain valve. Check every **ten minutes** the valve if automatic drain valve.
- Switch off the machine when do not use it.
- Clean oil, fuel or care products from, the machine, in particular the connections and screw joints, before carrying out maintenance/repair work. Do not use aggressive cleaning fluid. Use a fibre-free cleaning cloth.
- Completely remove all covers/seals after cleaning.
- Use only original fuses with specified current rating. If there is a failure in the electric energy supply, shut the machine/unit down immediately.
- Work on electric units or operating equipment may only carried out by a qualified electrician or by a person under the instruction and supervision of qualified electrician according to electric technical regulations.
- The electrical equipment of a unit must be regularly checked.
- When working in small rooms, observe any national regulations.
- Depressurize system and pressure lines before commencing repair work.
- With regard to oil, grease and other chemical substances, observe the relevant safety rules for the product.
- When switching on the machine, check the arrow to ensure correct direction of rotation of the drive motor.

5.4. Electrical installation:

For installation of electrical equipment observe the following:

In the annex of this instruction manual you will find the standard schematic diagrams valid for the respective compressor unit.

Observe regulations of local electricity supply company.

Connection must be carried out by an expert only.

Ensure correct installation of protective conductor.

Check conformity of motor and control device tension and frequency with those of electric network.

ATTENTION: check the correct direction of the fan.

6. OPERAZIONI PER L'AVVIAMENTO:**6.1 Preparation for operation.**

WARNING: this machine is built to produce breathing air. It is not suitable for compression of oxygen. Explosion occurs if an oil lubricated compressor is operated with pure oxygen or gases with oxygen content of more than 21%!

All compressor units are tested prior to delivery to the customer, so after correct installation of the unit there should be no problem putting it into operation, observing the following points:

Prior to first operation read Instruction Manual carefully. Make sure that all persons handling the compressor and the filling station are familiar with the function of all controls and monitors.

Immediately after switching on the system for the first time check the direction of rotation of the motor for compliance with the arrow on the unit. If motor turns in the wrong direction, the phases are not connected properly. Shut down unit immediately and interchange two of the three phase leads in the switch box. Never change leads at the motor terminal board.

Prior to each operation check the oil level. Only for petrol unit: - check engine oil level according to manufacturer's instruction manual - check fuel tank. Top up if necessary - open fuel shut-off valve.

Every time the unit is started up check all systems for proper operation. If any malfunction is observed stop unit immediately and find the cause of the fault or call the service department.

6.2. Starting the unit:Unit with electric engine without compressor control system:

The motor is switched on manually by pressing the start button. Machine does not be left alone during working. Check continuously the right function.

On units without automatic condensate drain, the manual condensate drain valves have to be opened before starting the unit, as soon as the unit is running the valves can be closed again. Every 8/10 min drain the valves.

Units with electric engine with automatic control system:

This model is delivered with an automatic control system.

Before starting check point 6.1 and then press ON button. Switch off the machine pressing STOP button.

Units with petrol engine:

Open condensate drain valves on the filters to release pressure, so that motor start without load. Set choke to position START. Start engine with recoil starter or crank handle. As soon as motor runs smoothly return choke to normal operating position.

For all units:

Close condensate drain valves tightly and run unit to final pressure. Check final pressure safety valve and pressure gauge. As soon as final pressure is reached and final pressure safety valve blows off, open condensate drain valves and drain condensate - unit is ready for filling operation.

7. FILLING PROCEDURE:**7.1. Connecting the bottles:**

WARNING: Filling hoses must be in satisfactory condition and threads undamaged. Pay particular attention to damage on the interface from hose fitting to hose. If the rubber is scored, hose must be discarded otherwise water can enter and attack wire gauze causing it to rust.

Normally connectors are allowed for pressures up to 200bar (2.850psi).

Please follow the process below:

- Connect air bottle to filling valve.
- Open filling valve.
- Open bottle valve-bottle will be filled. .
- Switch on the compressor.
- Upon reaching final bottle pressure close bottle valve first, then filling valve by returning handle to closed position.
- Remove compressed air bottle.
- Depressurize unit before opening valve-A to avoid damage to the change - over device.

If it is necessary more pressure of 220bar please ask for the suitable material: safety valves and connectors are different.

8. MAINTENANCE :**8.1. Maintenance record:**

We recommend that all maintenance work is recorded in a service book, showing the date and details of the work carried out. This will help to avoid expensive repairwork caused by missed maintenance work.

Please fill in the appropriate lines to show what maintenance work has been carried out, and sign and date.

Remember:

- 1- always shut down and decompress the complete system prior to carrying out any work on the compressor;
- 2- never repair pressure lines by soldering or welding;
- 3- only use original spares for maintenance or repair work.



8.2. Maintenance schedule:

<i>After first 25 operating hours</i>	<i>Date</i>	<i>Signature</i>
Clean intake filter and intake filter cartridge		
Check Oil level (Max. RED POINT)		
Cartuccia Filtro Carboni – setaccio		
Check tightness of all cooler-pipes and couplings		
Check tightness of O-rings		
Check functioning and tightness of filling valve		
Check zero position on final pressure gauge when depressurized		

<i>After first 50 operating hours, at least annually</i>	<i>Date</i>	<i>Signature</i>
Oil change 350 ml.		
Check and clean intake filter element 1st stage		
Check filter and cartridge		

<i>After first 500 operating hours, at least annually</i>	<i>Date</i>	<i>Signature</i>
Valve change		
Change intake filter element 1st stage		
Check blow-off pressure of final pressure safety valve		

<i>After repair work</i>	<i>Date</i>	<i>Signature</i>
Check functioning and tightness of filling valve		
Clean intake filter element 1st stage		
Check tightness of O-rings		
Check zero position on final pressure gauge when depressurized		

9. MAINTENANCE WORK

This chapter contains the maintenance work as well as short functional description for each component.

9.1. Lubrication :

The lubrication system is a **Splashed lubrication**. Mechanic lubrication by connecting-rod movement. Connecting-rod has a metal piece below that splashing in the oil during the fast movement causes a spray inside the cylinder.

9.2. Type of oil :

Using the correct oil is of vital importance for life and maintenance of the compressor. Nardi has a particular oil studied and tested for the best operation of his machine. Depending on the application of the compressor the requirements placed on the oil are:

- low deposits
- No carbonizing effect, especially in the valves
- Good anti-corrosive properties
- For breathing air application, also physiological and toxicological suitability.

Due to the thermal load on the compressor only high quality oil should be used. You are recommended to restrict oils to those which have been approved by us: oil for not mixed air (21% O₂).

9.3. Oil change :

Please follow the procedure as below:

- Ensure to have a sufficient quantity of oil.
- Run compressor warm.
- Remove red cap from oil filler neck and drain oil while still warm by means of oil drain plug.
- Remove oil filter.
- Mount a new filter element.
- Fill new oil though filler neck to Max.—mark at sight gauge.

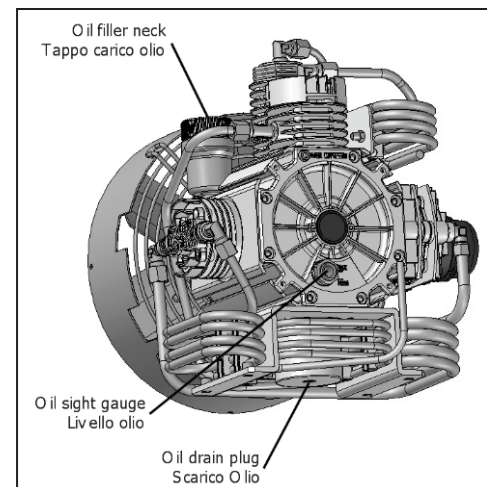

9.4. Changing the oil type:

To avoid severe damage to the compressor unit when changing the oil type, the following measures should be strictly adhered to:

- Follow the procedure Chapter 9.3.
- Change or clean all parts with old oil.
- After approx. 10 operating hours check lubricating oil for degree of contamination, and change oil again if necessary.
- Fill compressor with the new oil and do not mix different oils.
- Refill compressor with same oil, only.

9.6. Intake filter

A dry micronic filter is used to filter intake air. The filter cartridge must be cleaned or changed at regular intervals according to maintenance schedule. Do not use any cleaning fluids which are a hazard to respiration.

Please clean intake filter as following:

- Remove micronic filter cartridge.
- Clean with brush or by blowing air inside out.
- Change with a new filter and make sure that top cover is installed properly.

9.7. Intermediate separator

Separators are designed to remove water and oil accumulation due to cooling the air down after the compression process. An intermediate separator is mounted on the compressor between stages.

Clean filter element as follows:

- Switch off the compressor and depressurize separators.
- Remove piping connected to filter head. Screw off union nut. Remove filter head.
- Clean filter element using hot soapy water and blow dry with compressed air.
- Replace O-ring.
- Close the filter strongly.

9.8. Coal filter cartridge :

Coal filter cartridge removes water condensation and oil by a chemical system not mechanical. Activated carbon and molecular sieve absorb water and oil purifying breathing air according to DIN EN12021.

The filter system is subject to dynamic load. It is designed for a certain number of load cycles, which originate from an abrupt pressure loss at condensate drain. After 500 operating hours an inspections have to be arranged by the operator. After reaching the max. number of load cycles: 8000 cycles at 300Bar or 21000cycles at 225Bar the filter assembly must be replaced. Approximately, with 4cycles per hour at 300 bar filter must be changed after 2000 operating hours instead at 225 Bar after 5000 operating hours..

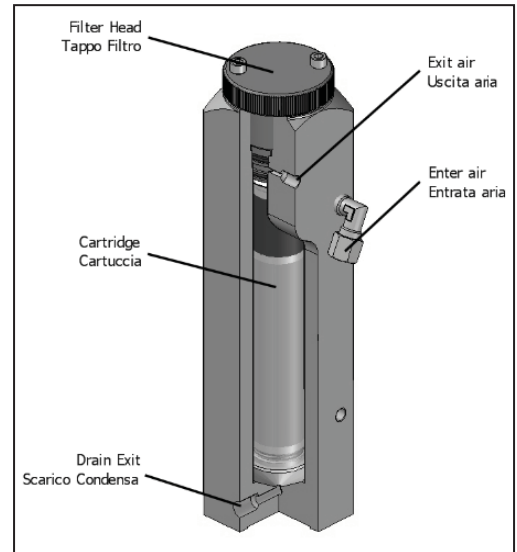

9.9. Filter maintenance :

The cartridge in the picture removes water and oil

Please follow the procedure below:

- Depressurize system before starting any maintenance work.
- Dry inside of filter housing with a clean cloth before installing new cartridge and check for corrosion. Change if necessary.
- Check the O-ring and change it if damaged.
- Change cartridge before reactivating a compressor unit.

The number of operating hours or the amount of possible bottle fillings per filter cartridge can be determined taking into consideration the ambient temperature and the cartridge used.

To avoid any danger to your health or damage to your unit, change used up cartridges in good time. Never fill used up cartridges yourself. The filter material was chosen specifically by Nardi compressori for each kind of application. Never remove replacement cartridge from packaging prior to actual use otherwise highly sensitive molecular sieve will absorb water vapour from surrounding air and cartridge saturated.

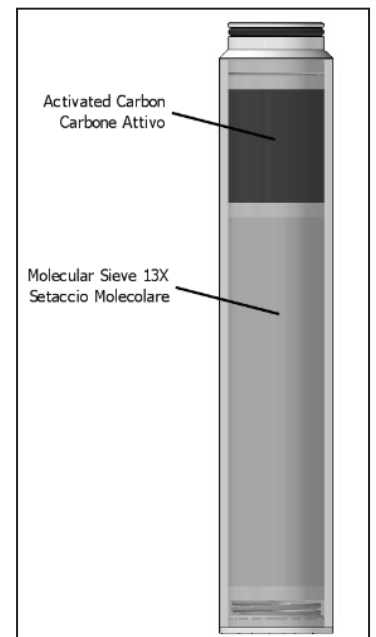

9.10. Lifetime of filter cartridge :

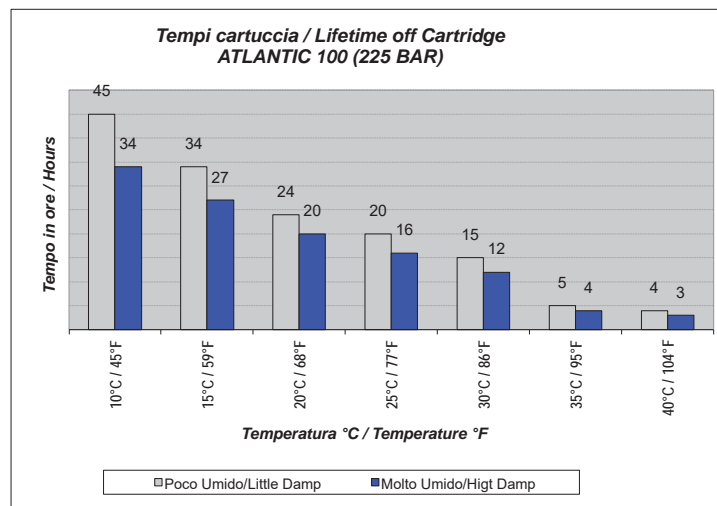

9.11. Valves:

The valve heads of the individual stages form the top part of the cylinders. The intake and pressure valves are fitted inside the valve heads. Note that the valves are operated by the flow of the medium. On the suction stroke, the intake valves open and the medium flows into the cylinders. At the start of the compression stroke the intake valve closes and the medium opens the pressure valve.

Please follow the instructions below for changing the valves:

Always replace valves as a complete set.
Carefully clean dirty valves.

9.12. Valve change:

Changing the valve of the 1st stage:

Put the attention at the picture and check that the mark 'T' is really at the top. Remove gaskets and O-rings if damaged.

Changing the valve of the 2nd stage:

Please follow the procedure below:

- Unscrew the intake and pressure lines from the cylinder head.
- Unscrew the screw of valve-cover.
- Clean intake and pressure valves and check for wear. Valve seats and plate valves must not show any signs of wear or damage. Replace damaged parts.
- Assembly is performed in the reverse sequence of removal.
- Check the pressure valve function and stroke by lifting the valve plate.
- Check O-rings and replace them if damaged.
- Fix the valve-cover.

Reconnect the intake and pressure lines.

Changing the valve of the 3rd – 4th stage:

Please follow the procedure below:

- Unscrew the intake and pressure lines from the cylinder head..
- Fix the head
- Unscrew the intake valve body.
- Clean intake and pressure valves and check for wear. Valve seats and plate valves must not show any signs of wear or damage. Replace damaged parts.
- Assembly is performed in the reverse sequence of removal.
- Peen the cylinder head on the screw.
- Check the pressure valve function and stroke by lifting the valve plate.
- Check O-rings and replace them if damaged.
- Fix the head at cylinder.
- Reconnect the intake and pressure lines.

Observe the correct sequence when fitting together again.

Check individual components for excessive wear. If the valve seat and valve disks are dented, replace the valves.

Use only satisfactory gaskets and O-rings on reassembly.

After finishing all maintenance work on the valves, turn the compressor manually and check whether all items have been correctly installed. After 30 minutes after starting, switch off the unit and check again.

Replace the valves every 500 operating hours to avoid fatigue failure.

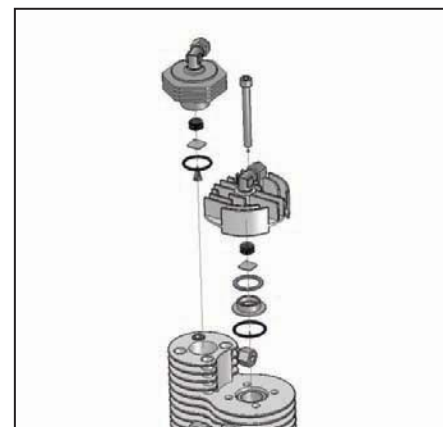
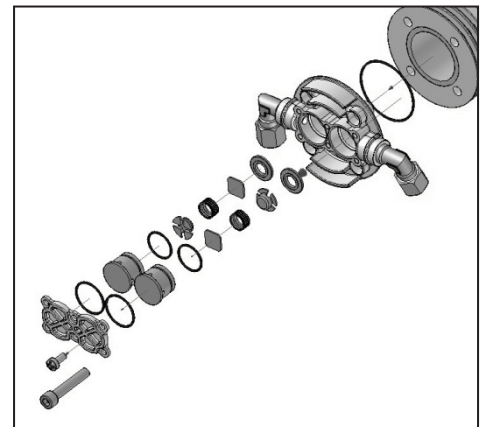
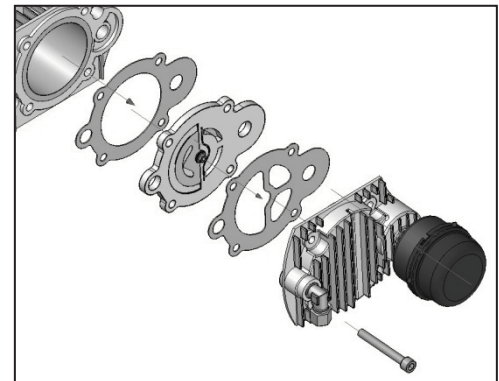

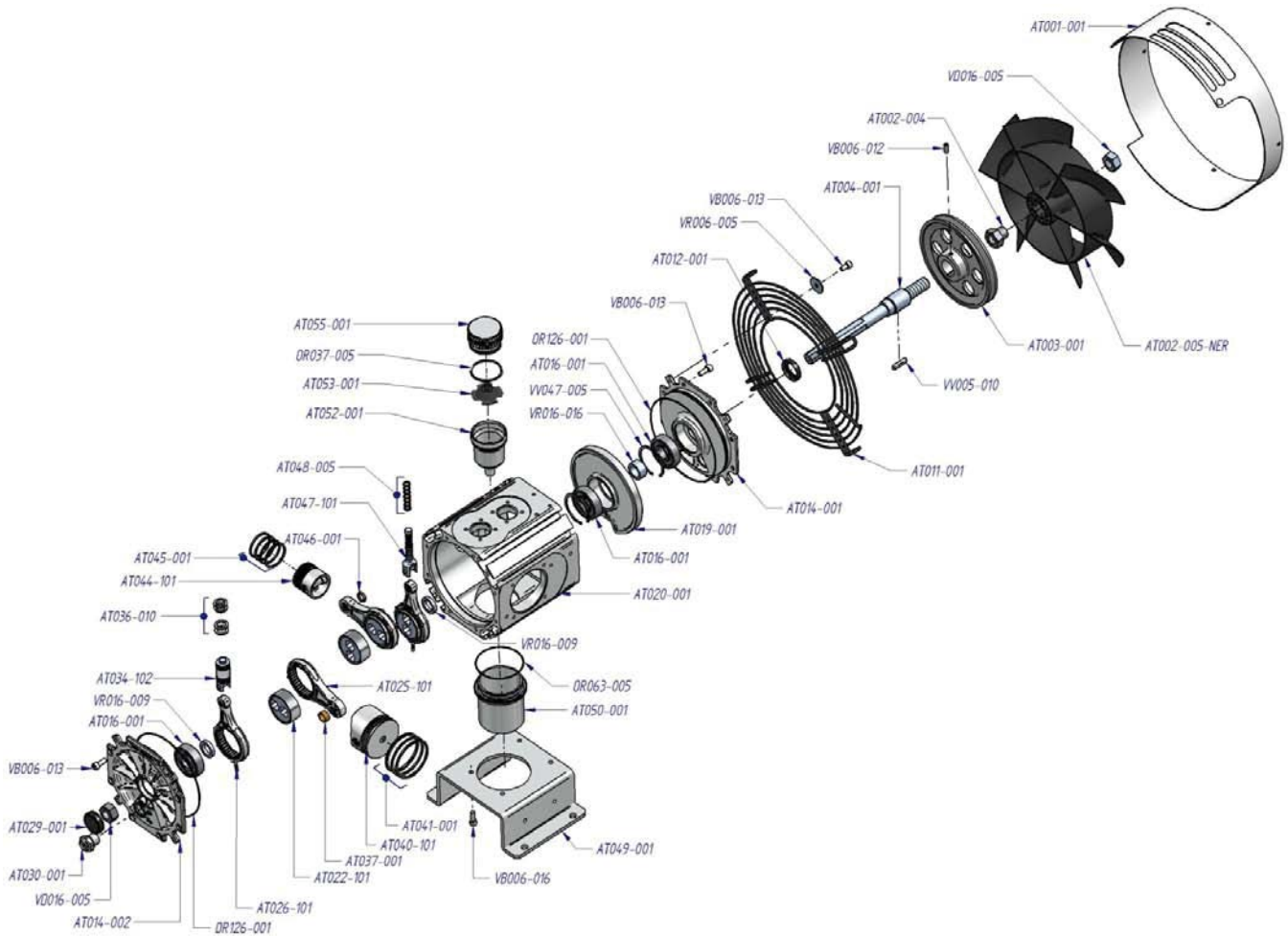

CODE	DESCRIPTION	CODE	DESCRIPTION	CODE	DESCRIPTION
AT001-001	Metal Cover Fan	AT029-001	Cover Oil seal	AT053-001	Flange Oil vapour
AT002-005-NER	Fan	AT030-001	Visual level plug oil	AT055-001	Oil filler cap
AT002-004	Nut for fan	AT034-102	Piston 3rd stage with pin for cast-iron rings	OR037-005	O-ring
AT003-001	Pulley	AT036-010	SET Piston rings 3rd stage cast-iron	OR063-005	O-ring
AT004-001	Compressor shaft	AT037-001	Thickness connecting rod 1st stage	OR126-001	O-ring
AT011-001	Metal Wire	AT040-001	Piston 1st stage with pin	VB006-012	Screw
AT012-001	Oil seal	AT041-001	SET Piston rings 1st stage	VB006-013	Screw
AT014-001	Flange	AT044-001	Piston 2nd stage with pin	VB006-016	Screw
AT014-002	Flange	AT045-001	SET Piston rings 2nd stage	VD016-005	Nut
AT016-001	Bearing	AT046-001	Thickness connecting rod 2nd st.	VR006-005	Thickness
AT019-001	Flange	AT047-001	Piston 4th stage with pin	VR016-009	Thickness
AT020-001	Compressor crankcase	AT048-005	SET Piston rings 4th stage	VR016-016	Thickness
AT022-001	Handspike socket whit ring	AT049-001	Bracket Compressor	VV005-010	Key
AT025-001	Connecting rod 1st - 2nd St. with bearing	AT050-001	Oil cap	VV047-005	Safety O-ring
AT026-001	Connecting rod 3rd - 4th St. with bearing	AT052-001	Vat Oil Vapour		

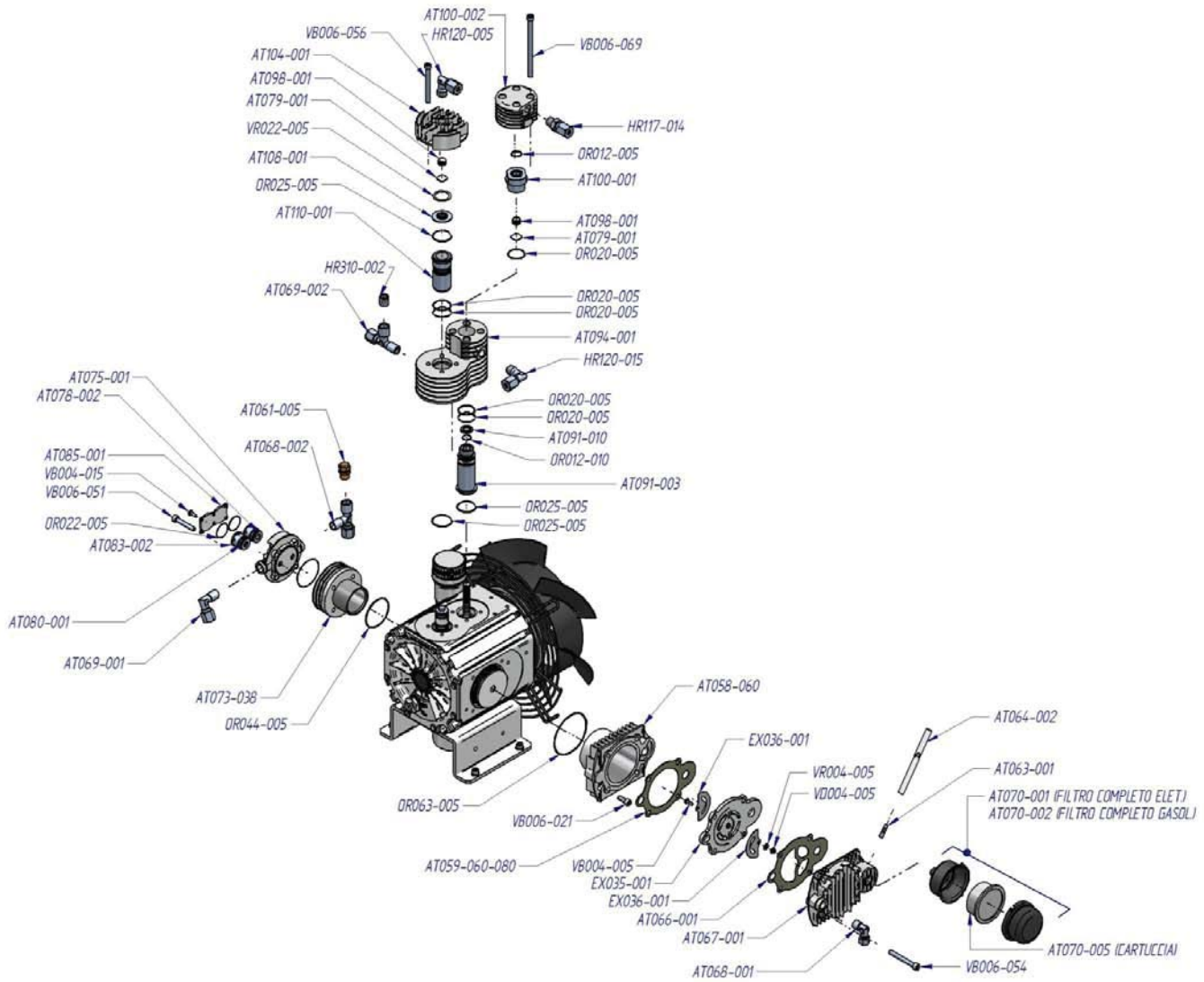

CODE	DESCRIPTION	CODE	DESCRIPTION	CODE	DESCRIPTION
AT058-060	Cylinder 1st Stage	AT083-010	Suction valve 2 nd stage	HR310-002	Closure plug 1/4"
AT059-060-080	Cylinder Gasket 1st Stage	AT083-020	Aspiration valve 2 nd stage	OR012-005	O-ring
AT061-005	Safety valve 2nd stage	AT085-005	Cover valves	OR012-010	O-ring
AT064-002	Tube	AT091-001	Cylinder 4 th stage	OR020-005	O-ring
AT066-001	Top Gasket 1 st stage	AT091-010	Inferior body valve 4 th stage	OR022-005	O-ring
AT067-001	Head 1 st stage	AT094-001	Aluminum cylinder 3 rd - 4 th stage	OR025-005	O-ring
AT068-001	Connection L 1/4" tube 10mm	AT098-001	Spring valve 4 th stage	OR043-005	O-ring
AT068-002	Connections T 1/4" tube 10mm	AT100-001	Inside head 4 th stage	OR044-005	O-ring
AT069-001	Connections L 1/4" tube 8mm	AT100-002	Head 4 th stage	OR063-005	O-ring
AT069-002	Connection a T 1/4"	AT104-001	Head 3 rd stage	VB004-015	Screw
AT070-001	Complete suction Filter for electric mod.	AT108-001	Inferior body valve 3 rd stage	VB006-021	Screw
AT070-002	Complete suction Filter for gasoline mod.	AT108-002	Ring valve 3 rd stage	VB006-051	Screw
AT070-005	Filter cartridge	AT110-001	Cylinder 3 rd Stage	VB006-054	Screw
AT073-038	Cylinder 2 nd stage	EX035-101	Valve plate complete 1st stage	VB006-056	Screw
AT075-001	Head 2 nd stage	HR117-014	Pipe fitting direct 1/4" for tube 6 mm	VB006-069	Screw
AT079-001	Valve disc 3rd stage	HR120-005	Pipe fitting "L" 1/4" for tube 8 mm	VR022-005	Screw

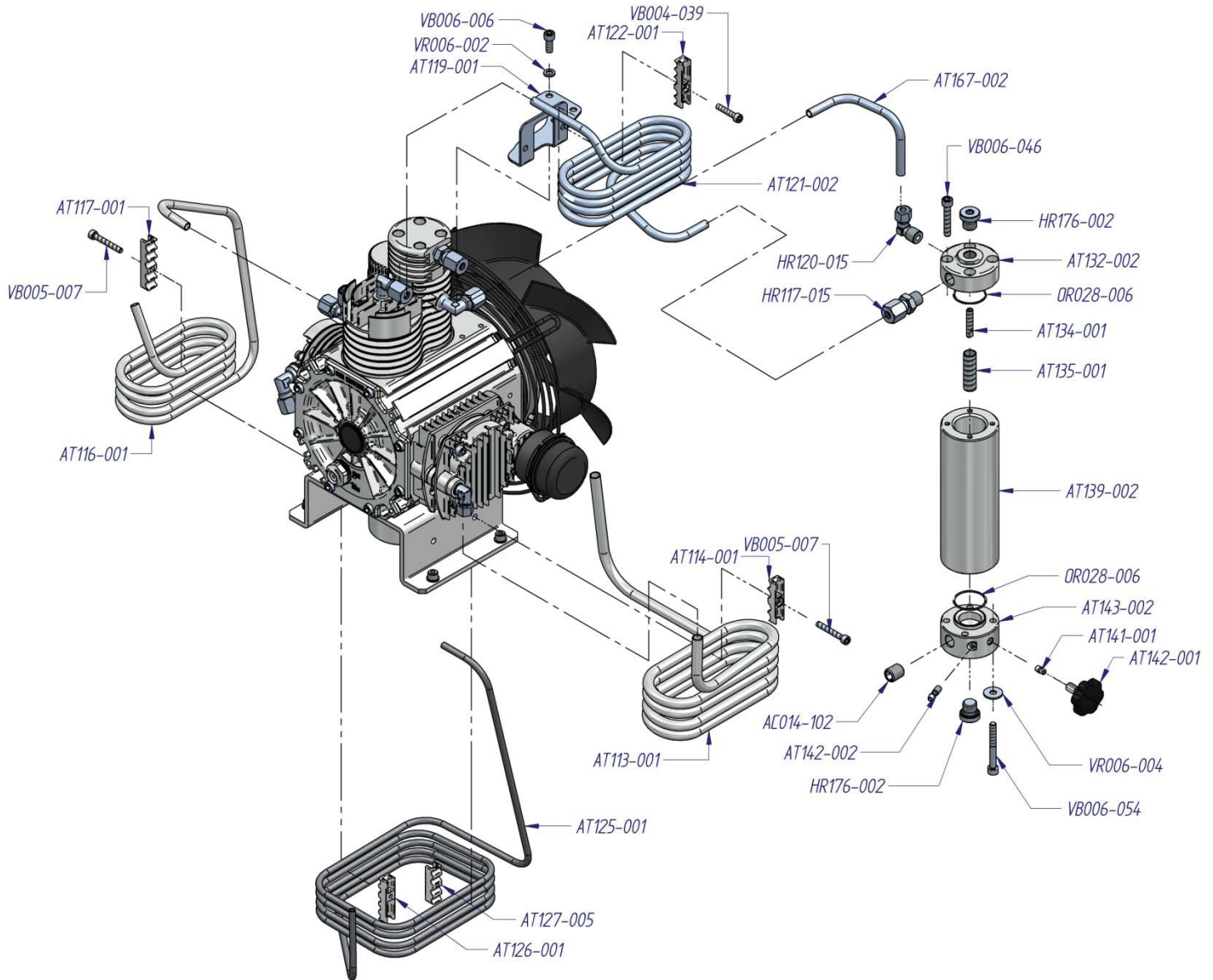

CODE	DESCRIPTION	CODE	DESCRIPTION	CODE	DESCRIPTION
AC014-102	Closure plug	AT134-001	Aluminum tube separator	VB004-039	Screw
AT113-001	Cooling tube	AT135-001	Aluminum tube separator	VB005-007	Screw
AT114-001	Support cooling tube	AT139-002	Body filter separator	VB006-006	Screw
AT116-001	Cooling tube	AT141-001	Rilsan nut	VB006-046	Screw
AT117-001	Support cooling tube	AT142-001	Black screw of discharge	VB006-054	Screw
AT119-001	Bracket cooling tube	AT142-002	Condensate drain tube	VR006-002	Washer
AT121-002	Cooling tube	AT143-002	Base filter separator	VR006-004	Washer
AT122-001	Support cooling tube	AT167-002	Tube separator		
AT125-001	Cooling tube	HR117-015	Pipe fitting 1/4" tube diam.8 mm		
AT126-001	Support cooling tube	HR120-015	Pipe fitting "L" 1/4" tube diam.8 mm		
AT127-005	Support cooling tube	HR176-002	Closure plug		
AT132-002	Closure plug filter separator	OR028-010	O-ring		

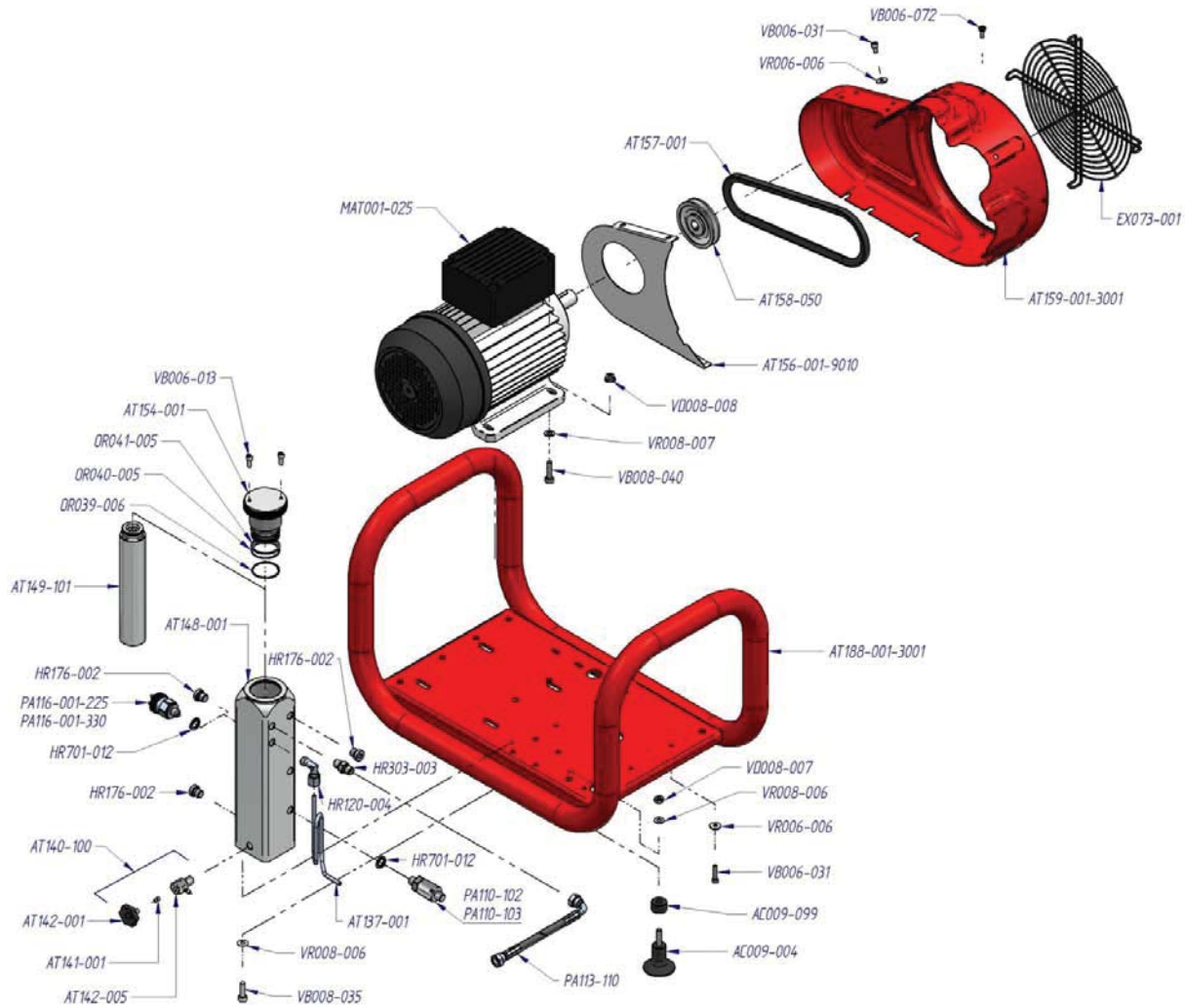

CODE	DESCRIPTION	CODE	DESCRIPTION	CODE	DESCRIPTION
AC009-004	Rubber foot with thread	AT159-001-3001	Cover belt electric model	PA113-110	Filling hose
AC009-099	Plastic washer	AT188-001-3001	Frame Atlantic P	PA116-001-225	Pressure swich 225 BAR
AT137-001	Tube	EX073-001	Metal protection	PA116-001-330	Pressure swich 330 BAR
AT140-001	Drain valve housing	HR120-004	Pipe fitting "L"	VB006-013	Screw
AT141-001	Rilsan nut	HR176-002	Closure plug 1/4"	VB006-031	Screw
AT142-001	Black screw of discharge	HR303-003	Connection	VB006-072	Screw
AT142-005	Drain valve housing	HR701-012	Washer	VB008-035	Screw
AT148-001	Body filter Atlantic	MAT001-025	Electric motor 230 Volt 50 Hz	VB008-040	Screw
AT149-101	Filter cartridge - electric	MAT001-030	Electric motor 230 Volt 60 Hz	VD008-007	Nut
AT154-001	Plug filter Atlantic	OR039-006	O-ring	VD008-008	Nut
AT156-001-9010	Metallic cower belt	OR040-005	O-ring	VR006-006	Washer
AT157-001	Belt for electric engine 50/60 Hz	OR041-005	O-ring	VR008-006	Washer
AT158-050	Pulley for electric engine 50 Hz	PA110-102	Safety valve PN 200 Bar	VR008-007	Washer
AT158-060	Pulley for electric engine 60 Hz	PA110-103	Safety valve PN 300 Bar		

HOW TO INSTALL U.S. PLUG FOR THE ATLANTIC COMPRESSOR 220 V SINGLE PHASE

- 1) Remove the European plug;
- 2) Take the three wires: the green/yellow wire attached to the ground and connect the other two wires to the remaining blades as pictures below:



Note: this plug can be purchased in any hardware store or at Home Depot: NEMA 6-20P