

IZH MP-661K Drozd & Drozd Blackbird owner's manual



IZH 661K Drozd



IZH 661K Drozd
Blackbird



18370 S. Miles Rd
Warrensville Heights, OH 44128
216-220-1180

Record the serial
number of your airgun.....



Follow the warnings and safety procedures shown here and throughout this manual.

Not a toy. Adult supervision required. This airgun is intended for use by those 18 years of age or older. Misuse or careless use may cause serious injury or death. May be dangerous up to 500 yards.

Do not use this airgun until you have read and understood this owner's manual.

Use steel BBs for your airgun. Never reuse BBs. The use of any other kind of ammunition can cause injury to you or damage to your airgun.

Keep your finger off the trigger while cocking your airgun. When you are sure of your target and backstop and the area around the target is clear, you may activate the on/off switch and squeeze the trigger to fire. Always keep your the switch in the OFF position until you're ready to shoot.

Remember to place your target carefully and THINK about what you will hit if you miss the target.

Do not assume your airgun is unloaded if it fails to fire properly!

Never leave your airgun loaded. Always treat an airgun as if it is loaded, even if you think it is not. Always transport your airgun unloaded and in a hard case.

Never point an airgun at another person or in an unsafe direction.

This airgun has an on/off switch that functions like a manual safety. However, YOU are the ultimate safety for your gun.

You and others with you should always wear safety glasses to protect your eyes.

Do not shoot at hard surfaces or at the surface of water. The BB may bounce or ricochet and hit someone or something you did not intend to hit.

Always choose your target carefully. It is best to shoot at paper targets attached to a safe backstop or a trap intended to safely stop and/or capture steel BBs. Your backstop should be checked for wear before and after use. Replace your backstop if the surface is worn or damaged or if a ricochet occurs.

Do not disassemble, tamper with or attempt to repair or modify your airgun. Doing so may void your warranty and may result in injury. Contact Air Venturi at 216-220-1180 for repair.

In the unlikely event your airgun malfunctions or exhibits reduced performance, DO NOT attempt to fix the problem yourself. Call Air Venturi at 216-220-1180 so we can address any issues or have you return your airgun for repair.

Children are attracted to and can operate guns that can cause severe injuries or death.

Prevent child access by always keeping guns locked away and unloaded when not in use.

If you keep a loaded gun where a child obtains and improperly uses it, you may be fined or sent to prison.

The IZH MP-661K Drozd and MP-661K Drozd Blackbird are CO₂-powered guns with 3 firing modes: semi-auto, 3-round full-auto burst and 6-round full-auto burst. The standard Drozd comes with a 30-round BB magazine and uses a single 12-gram CO₂ cartridge. The Drozd Blackbird comes with a 400-round BB hopper and uses either three (3) 12-gram CO₂ cartridges or one 88-gram CO₂ tank. Both guns require six (6) AA batteries.

The following information will explain the function, loading and operation of the Drozd and Drozd Blackbird. Where appropriate, we will point out any differences.

SIGHTS

Both versions have the same fixed front sight and a rear sight that is adjustable for windage and elevation. (1)

1



OPTICS

The standard Drozd has an 11mm optics rail that is 1.88 inches long. (1)

2

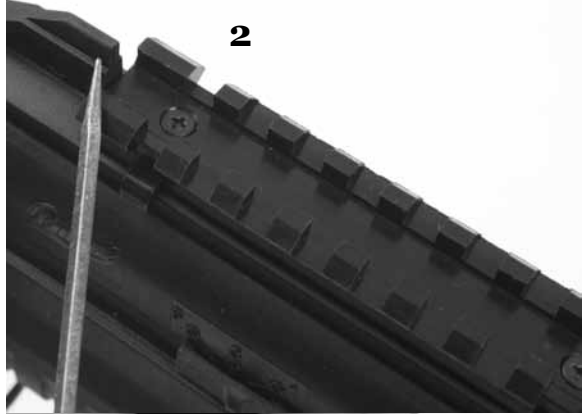

The Drozd Blackbird has a Weaver/Pictanny rail that runs the length of the space between the front and rear sights. (2)

MAGAZINE— PRESSURIZING & LOADING:

Standard Drozd

Do not touch the trigger or any other switches when loading the gun. The standard Drozd comes with a 30-round BB magazine that also holds a single 12-gram CO₂ cartridge. The magazine is in the grip, and you release it by pushing the release button on the grip. (3)

3



Flip back the magazine plate. Insert a 12-gram CO₂ cartridge in the magazine (see details shown in photos 4-11 on page 4). Align the tip of the CO₂ cartridge with the round port as shown in picture 5 and push the CO₂ cartridge down into magazine.



WARNING!
CO2 is a refrigerant. If the CO2 cartridges in your gun are not empty, they will expel all their CO2 when you remove them. Keep all body parts away from CO2 when it is expelled, as it is cold enough to freeze flesh!

Hold the cartridge in place (6) as you swing the lever at the bottom of the magazine into place. This will cause the CO2 cartridge to be pierced (you should hear a hissing sound when the cartridge is punctured).

To load the magazine with steel BBs, pull back and hold the spring-loaded follower (8) and load steel BBs into the magazine (9). Once loaded, swing the magazine plate back over the magazine and insert the entire unit into the gun's grip. (10)

**MAGAZINE—
PRESSURIZING &
LOADING:**

Drozd Blackbird

Do not touch the trigger or any other switches when loading the gun. The Blackbird's 400-round BB hopper is located in the gun's grip. Press the mag release button to separate the mag from the gun. The cord leading to the gun must also be unplugged from the forearm to remove the magazine. (12-13)

Once the mag is separated from the gun, pop open the trap door and pour in up to 400 steel BBs. Close the trap door to contain the loaded BBs. (14-15)

To clear any jams, click open the access door and remove the jammed BBs. (16)

To empty BBs from the hopper, turn it upside down, flip open the trap door & shake out the BBs. You will also have to open the access door (the one used to clear jams) to remove some of the BBs that didn't



come out when you shook the magazine. (16-17)

Do not touch the trigger or any other switches when pressurizing your gun. During this procedure, the cable that goes from the mag to the forearm of your gun should still be unplugged. (12)

You can use either three (3) 12-gram CO2 cartridges or one (1) 88-gram CO2 tank.

The CO2 fill port is on the back of the magazine. (18)

To use 12-gram CO2 cartridges, screw the threaded adapter into the CO2 port in the back of the magazine. (18)

Insert a 12-gram CO2 cartridge into each one of the hollows in the adapter. (19) If the cartridges don't fit, turn the ring at the bottom of the adapter counterclockwise to loosen the openings. When all 3 cartridges have been inserted, twist the adapter's ring clockwise until you hear a hissing sound. That means the cartridges have been punctured, and the gun is now pressurized.

To insert an 88-gram

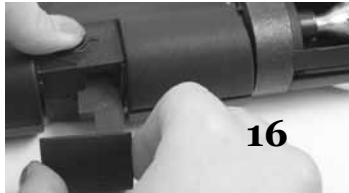

WARNING!

CO2 is a refrigerant. If the CO2 cartridges in your gun are not empty, they will expel all their CO2 when you remove them. Keep all body parts away from CO2 when it is expelled, as it is cold enough to freeze flesh!



21



22



23



24

CO2 tank, remove the 12-gram CO2 adapter and screw in the adapter for the larger CO2 tank. Insert the 88-gram CO2 tank into the adapter until you hear a hissing sound. The gun is now pressurized. (21-22)

Put the loaded and pressurized mag back into the gun and plug the cord into the forearm. (23-24)

SAFETY

On the left side of the receiver is an on-off switch that functions like a safety. It has a ON and OFF settings. ON allows the gun to fire. OFF disconnects the battery-operated switches (read those sections elsewhere in this manual). The cable from the magazine must be plugged into the forearm of the gun in order for the gun to fire.

MODES

Both guns have the same switches for firing modes: semi-auto, 3-round full-auto burst and 6-round full-auto burst.

On the left side of the receiver, there is a switch that has three (3) settings: 1, 3 and 6. To fire one round, push the switch to "1." This is the semi-auto mode. Each pull of the trigger will shoot one BB. If you push the switch to "3" or "6," the gun will be in full-auto burst mode. Either three or six BBs will be shot with each pull of the trigger. (26)

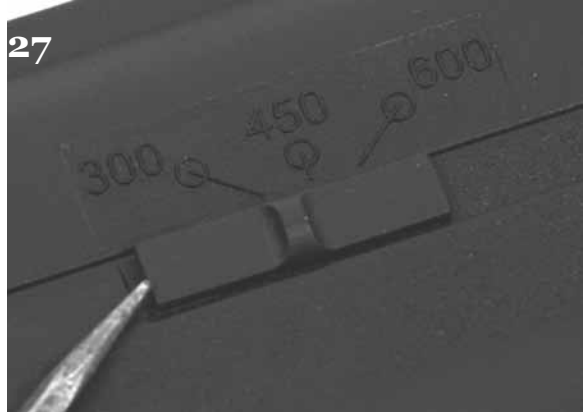
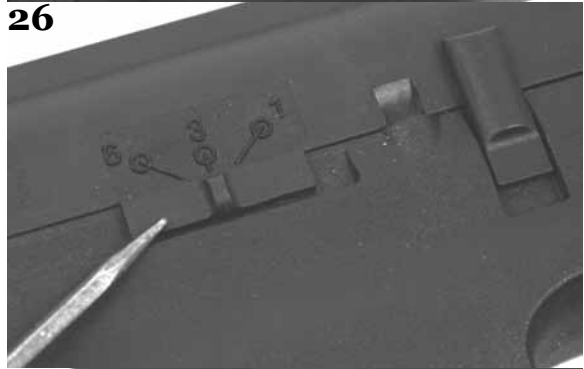

28



29

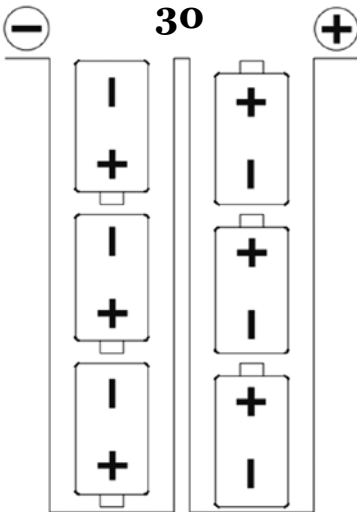

RATE OF FIRE

Both guns have a switch that lets you select the rate of fire (rounds per minute or rpm). The switch is on the right side of the receiver. (27)

The rates are 300, 450 and 600 rpm. Any of these rates affect the full-auto burst mode.

BATTERIES

Both guns use six (6) AA batteries. Under the muzzle of the gun, you'll find the battery compartment. Pull down on the compartment's front and then flip open the lid. Load three (3) batteries into each column. (28-29). Note the orientation of the batteries in the graphic on page 9. (30)

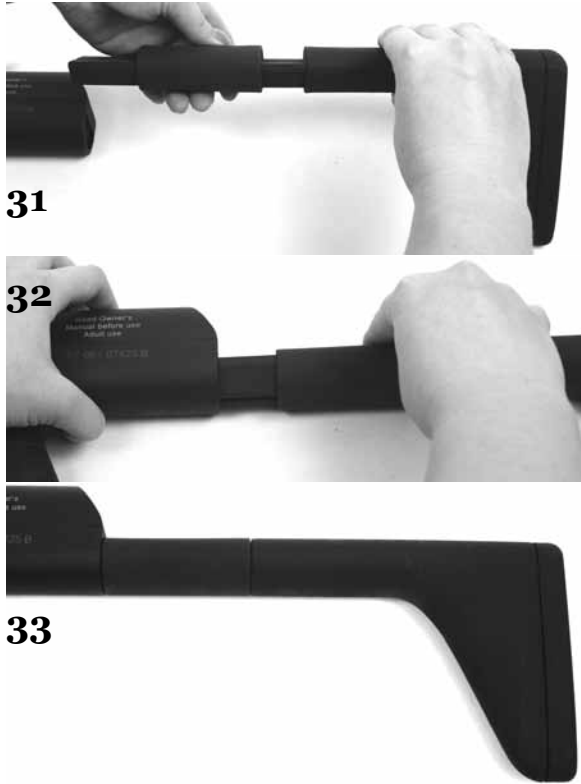

SHOULDER STOCK

The standard Drozd has a removable shoulder stock that's a two-piece unit. Connect the two pieces as shown in images 31 and 32 and insert the assembled unit into the back end of the gun's frame. (33) The gun may be used with or without the shoulder stock attachment.

MAINTENANCE

Clean the battery contacts every time you change batteries. If you do not plan to use the gun for an extended period of time or place the gun in storage, remove the batteries from the compartment. Use only new batteries and do not mix new and used batteries in the gun.

When inserting the 12-gram CO2 cartridges, put 2-3 drops of Crosman Pellgunoil on the tip of each cartridge. When inserting an 88-gram CO2 tank, put 5-6 drops of Crosman Pellgunoil on the tip. Pellgunoil lubricates the seals of the gun and will keep it functioning properly for years. Failure to properly lubricate the gun may result in early failure and CO2 leaking out of the gun.

Because you are shooting steel BBs, the barrel does not have to be cleaned.

**If you feel additional maintenance is required,
contact Air Venturi at 216-220-1180.**

Drozd side view

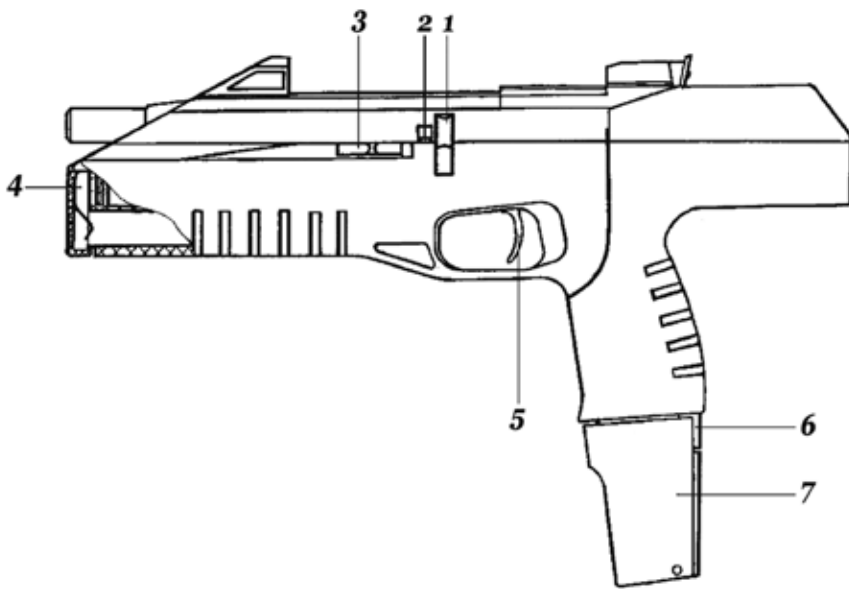

1. on/off switch
2. indicator light for on/off switch
3. semi-auto/full-auto switch
4. battery compartment cover
5. trigger blade
6. magazine catch
7. magazine

Drozd exploded view

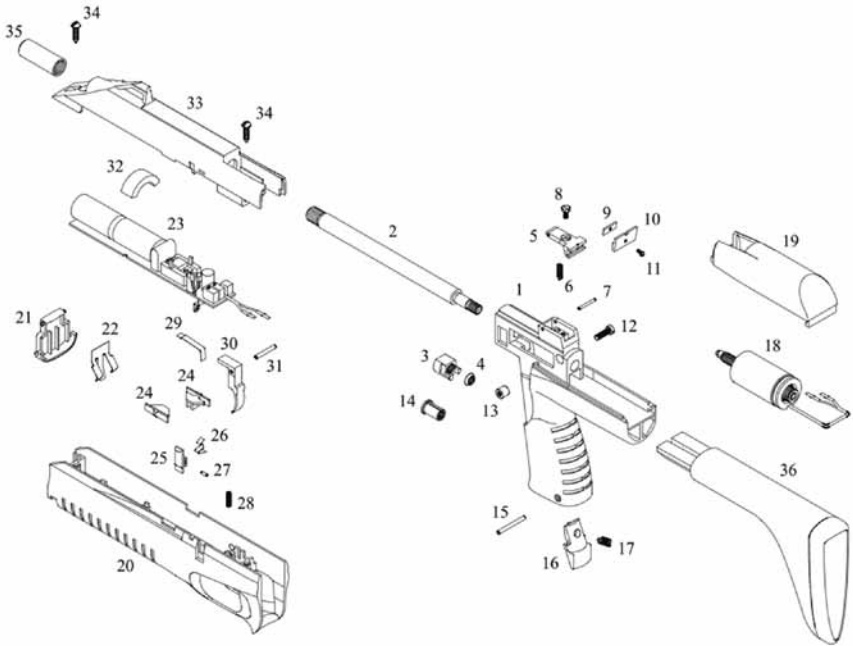

- | | |
|----------------------|---------------------------|
| 1. frame | 19. electromagnet cover |
| 2. barrel | 20. housing |
| 3. bushing | 21. cover |
| 4. barrel seal | 22. spring contact |
| 5. sight leaf | 23. electronic unit board |
| 6. spring | 24. switch |
| 7. pin | 25. button |
| 8. screw | 26. on/off switch spring |
| 9. plate | 27. pin |
| 10. rear sight blade | 28. ring spring |
| 11. screw | 29. clamp |
| 12. screw | 30. trigger |
| 13. nut | 31. pin |
| 14. insert | 32. cover |
| 15. pin | 33. cover |
| 16. catch | 34. screw |
| 17. spring | 35. muzzle |
| 18. electromagnet | 36. shoulder stock |

Warranty registration

Your IZH airgun is manufactured to the highest standards, using the finest materials to give a lifetime of service. In the unlikely event there are any defects in materials or workmanship in the first twelve (12) months after retail purchase, we will repair or replace your airgun under warranty. Keep your original purchase receipt.

What is covered: Replacement parts and labor. Transportation charges to consumer for return of repaired product.

The warranty will be invalid if:

- The airgun has been disassembled and incorrectly reassembled.
- The airgun is found to have lubrication not recommended by Air Venturi.
- The airgun has been fitted with non-Air Venturi parts.
- The airgun has been misused or abused.
- The warranty card was not returned within 30 days of retail purchase and/or the original purchase receipt cannot be presented.

The warranty does NOT cover:

- O-rings, screws, seals, springs or stocks.
- Any damages or faults caused by owner misuse or action.
- Shipment damage of the airgun to or from Air Venturi.
- Transportation charges to Air Venturi for defective products.
- Damages caused by abuse or failure to perform normal maintenance.
- Parts subject to normal wear and tear.
- Consequential damages, incidental damages or incidental expenses including damage to property.
- Any other expense.

Note: Some states do not allow the exclusion or limitation of incidental or consequential damages, so the above limitation or exclusion may not apply to you.

This warranty is in addition to your statutory rights. To register your warranty, the card below must be completed and returned to Air Venturi within 30 days of purchase. Retain your sales receipt as proof of purchase.

Warranty claims: Warranty claims for U.S. and Canadian Customers: Warranty card must be completed and mailed to Air Venturi within 28 days of purchase. Call Air Venturi at 216-220-1180 before returning any product.

Implied warranties: Any implied warranties, including the implied warranties of merchantability and fitness for a particular purpose, are limited in duration to one year from date of retail purchase.

Note: Some states do not allow limitations on how long an implied warranty lasts, so the above limitation may not apply to you.

To the extent any provision of this warranty is prohibited by federal, state or municipal law which cannot be preempted, it shall not be applicable. This warranty gives you specific legal rights, and you may also have other rights which vary from state to state and country to country.

Complete this warranty card and mail to Air Venturi, 18370 S. Miles Rd., Warrensville Hgts., OH 44128.

Warranty card for IZH-661K Drozd & Drozd Blackbird (checkmark box for the one you bought)

Serial number:.....Date of purchase:.....

Caliber:.....Where purchased:.....

Your name:

Your address:

.....

Your phone:

BASIC SAFETY RULES

1. Never point your airgun at anyone or allow anyone to point an airgun at you, even if you know it is not loaded.
2. Treat your airgun as if it's loaded, even if you know it's unloaded.
3. Aim your airgun in a safe direction.
4. Keep the muzzle of your airgun pointed in a safe direction.
5. Carry your airgun so the direction of the muzzle is under control, even if you stumble.
6. Keep your airgun unloaded until you are ready to shoot.
7. Check your airgun to make sure it's unloaded when you get it from another person or from storage.
8. Keep your finger off the trigger unless you are ready to shoot.
9. Everyone in the vicinity should wear safety glasses when an airgun is being used, shot or loaded.
10. You and others with you should always wear safety glasses to protect your eyes. If your reading or prescription glasses are not safety glasses, wear safety glasses over your other glasses.
11. This airgun has an on/off switch that functions like a manual safety. However, YOU are the ultimate safety for your gun.
12. Use steel BBs only. Never reuse ammunition.
13. Never leave a loaded airgun unattended.
14. Do not shoot at hard surfaces or at the surface of water. The BB may bounce off or ricochet and hit someone or something you had not intended to hit.
15. Place the backstop in a location that will be safe should the backstop fail.
16. Be sure of your target and what lies behind it before firing your airgun. Know what you will hit if you miss your target.
17. Your backstop should be checked for wear before and after each use. All backstops are subject to wear and will eventually fail. Replace your backstop if the surface is worn or damaged or if a ricochet occurs.
18. Do not attempt to disassemble or tamper with your airgun. Use an authorized repair center. Using unauthorized repair centers or modifying the function of your airgun in any way may be unsafe and will void your warranty.
19. Before you store your airgun, make sure that it is unloaded.

*Illustrations and photographs are for information purposes only
and may not show the exact model purchased.*



18370 S. Miles Rd
Warrensville Heights, OH 44128
216-220-1180