

Carl WALTHER GmbH

Sales

P.O.Box 2740
D - 59717 Arnsberg
Donnerfeld 2
D - 59757 Arnsberg
Phone +49 (0)2932 / 63 81 00
Fax +49 (0)2932 / 63 81 49

Service

P.O.Box 4325
D - 89033 Ulm
Im Lehrfeld 1
D - 89081 Ulm
Phone +49 (0)731 / 15 39 0
Fax +49 (0)731 / 15 39 109

All technical changes and modifications reserved.
Technische Änderungen vorbehalten.
Sous réserve de modifications techniques.
Queda reservado el derecho a realizar cambios.
Con riserva di modifiche tecniche.
Teknik değişiklik yapma hakkımız saklıdır.

Copyright © 2012 · Carl Walther GmbH

Achtung,
die Farben sind
keine Original-
Druckfarben

279 84 83.KW.02-13.0.5.21 Rev. a · Printed in Germany



DE

EN

ES

FR



INSTRUCTION MANUAL

AP20 AIR PISTOL

HAMMERLI®



DE

EN

ES

FR



®



The **AP20** air pistol is a product of

Carl WALTHER GmbH

Sales

PO Box 2740

Arnsberg 59717 Germany

Donnerfeld 2

Arnsberg 59757 Germany

Phone +49 (0)2932 / 63 81 00

Fax +49 (0)2932 / 63 81 49

Service

PO Box 4325

Ulm 89033 Germany

Im Lehrer Feld 1

Ulm 89081 Germany

Phone +49 (0)731 / 15 39 0

Fax +49 (0)731 / 15 39 109

Additional information about Carl WALTHER GmbH and our products can be found by visiting www.carl-walther.de or with the above contact information.

LEGAL INFORMATION

Despite due diligence information may change, even on short notice. Therefore, we assume no warranty or liability for the timeliness, accuracy or completeness of information.

The contents and design of the instruction manual are protected by copyright.

Any reproduction of the instruction manual or its contents requires the prior written permission of Carl WALTHER GmbH, insofar as the reproduction is prohibited by law.

© Copyrights 2012

Carl WALTHER GmbH, Ulm 89081 Germany

All rights reserved.

Text, images, graphics and their arrangement in this instruction manual are protected by copyright and other intellectual property laws.

The contents of this instruction manual may never be copied, distributed, modified or made accessible to third parties.



Read the instructions and warnings contained in this manual carefully before using the firearm.

TABLE OF CONTENTS

1	INTRODUCTION	5	DE
2	SAFETY INSTRUCTIONS	6	EN
2.1	About this instruction manual	6	ES
2.1.1	Notation and symbols	6	
2.2	Safety instructions	7	FR
2.2.1	General safety instructions	7	
2.2.2	Safety instructions for handling the weapon	7	
2.3	Intended use	9	
2.4	Liability and guarantee	9	
3	DESCRIPTION	10	
3.1	Construction	10	
3.2	Components	10	
3.2.1	Sights	10	
3.2.2	Barrel	10	
3.2.3	Trigger	11	
3.2.4	Grip	11	
3.2.5	Compressed air tank	11	
3.3	Package contents	11	
3.3.1	Standard equipment and included accessories:	11	
3.3.2	Accessories	11	
4	HANDLING	12	
4.1	Initial operation	12	
4.2	Conducting a safety inspection	12	
4.2.1	Inspecting the load status using the safety line	12	
4.3	Shooting	13	
4.3.1	Cocking and loading the pistol	13	
4.3.2	Halting shooting operations	14	
4.3.3	Unloading the pistol	14	
4.3.4	Storing the pistol	14	
5	ADJUSTING THE PISTOL TO THE USER	14	
5.1	Adjust grip	15	
5.1.1	Adjusting the hand rest	16	
5.1.2	Adjusting the palm rest	16	

5.2	Reconfigure the pistol for left-handed shooters	16
5.2.1	Dismantling the grip	16
5.2.2	Reconfiguring the hand rest and the palm rest	16
5.2.3	Reconfiguring the cocking lever	17
5.2.4	Mounting the grip	17
5.3	Adjusting the sight	18
5.3.1	Adjusting the integral front sight	18
5.3.2	Adjusting the rear sight	19
5.3.3	Rear sight fastening and relocation	19
5.3.4	Adjusting the height	20
5.3.5	Side correction	20
5.3.6	Adjusting the rear sight cut-out width	20
5.4	Reconfiguring the pressure reducer	21
5.4.1	Empty any remaining air from the pistol's pressure reducer.	21
5.4.2	Reconfigure the pressure reducer	21
5.5	Adjusting the trigger	22
5.5.1	Adjusting the trigger carrier	23
5.5.2	Adjusting the position carrier base	24
5.5.3	Changing the trigger travel	24
5.5.4	Increase the trigger pull weight	24
5.5.5	Adjusting the trigger stop	25
5.5.6	Adjusting the pawl intersection	25
5.5.7	Training trigger	25
5.6	Changing the barrel sleeve	26
6	COMPRESSED AIR TANK	27
6.1	Safety instructions for handling compressed air tanks	27
6.2	Filling the compressed air tank	28
6.3	Testing the pressure in the compressed air tank	28
6.4	Emptying the compressed air tank	29
7	MAINTENANCE	29
8	STORAGE AND TRANSPORT	30
8.1	Storage	30
8.2	Transport	30
8.2.1	Aircraft transport	30
9	TECHNICAL DATA	30
10	ACCESSORIES	31

1 INTRODUCTION

DEAR SPORT SHOOTER,

Thank you for choosing a Hämmerli product. The AP20 air pistol combines the latest technical innovations with tried-and-tested, advanced functions.

We are confident that you have selected an extremely high-quality air pistol that sets the standard for quality and development. Enjoy your new sport firearm, best of luck and “aim true”.

Your team at Carl WALTHER

DE

EN

ES

FR

2 SAFETY INSTRUCTIONS

2.1 ABOUT THIS INSTRUCTION MANUAL

This instruction manual describes the design, adjustment, handling and maintenance of the AP20 air pistol. The terms 'pistol' and 'weapon' will also be used.

The instruction manual is part of the pistol and must always be stored with the weapon for reference anytime before using.

2.1.1 Notation and symbols

This instruction manual points out specific hazards associated with the handling of a weapon. Hazard warnings are labeled as follows:

HAZARD

This pictogram with the word "**DANGER**" designates a direct hazard with **high risk**, which can result in immediate death or severe bodily injury if not avoided.

▶ This arrow points to the corresponding measure for averting the direct hazard.

WARNING

This pictogram with the word "**WARNING**" designates a potential hazard with **moderate risk**, which can result in severe bodily injury if not avoided.

▶ This arrow points to the corresponding measure for averting the potential hazard.

CAUTION

This pictogram with the word "**CAUTION**" designates a hazard with **low risk** which can cause minor or moderate bodily injury if not avoided.

▶ This arrow points to the corresponding measure for averting the hazard or property damage.

The locations of instructions and information that are of particular importance as well as tips for making protection easier through the described handling steps are labeled as follows:

NOTE

This pictogram "**NOTE**" provides tips and recommendations for use and handling.

2.2 SAFETY INSTRUCTIONS

The AP20 air pistol was developed with state-of-the-art weapons technology according to recognized guidelines for the safety and protection of the user.

Nevertheless, it is still a weapon and for this reason may only be used by persons who have completely read and understood this instruction manual. Its use must occur with utmost caution and in compliance with the safety instructions described in this instruction manual as well as government regulations in your country.

HAZARD**MORTAL DANGER**

Thoughtless actions can result in severe danger to the life of the user and other persons as well as in damage to the surrounding environment.

► Carefully read and commit to the following safety instructions during handling.

2.2.1 General safety instructions

- Observe and comply with government regulations in your country for handling weapons and ammunition.
- Thoroughly and completely read the instruction manual before using the pistol. Only use the pistol if the instructions are absolutely clear.
- Always store this instruction manual with the pistol.
- Also store any supplemental information or additions to this instruction manual with the pistol.
- Be sure to include the instruction manual with any hand over of the pistol to another user or owner.
- Only allow persons who have completely read and understood this instruction manual access to the pistol.
- Refrain from shooting or handling the weapon when under the influence of medication, drugs or alcohol.

2.2.2 Safety instructions for handling the weapon

- Always wear hearing protection and safety goggles when shooting. Call to the attention of persons in the area the need for hearing protection and safety goggles.
- Store pistols and ammunition in compliance with the law. Unauthorized persons (especially children) may not gain access to the pistol.
- Do not shoot at flat surfaces like rocks, concrete, walls, doors, glass or even water. The bullet may penetrate or ricochet in an unpredictable direction.

- Before shooting or cleaning and in case of malfunction always ensure that the pistol is not loaded and the barrel is free of foreign bodies (see Chapter 4.2).
- Treat an unloaded pistol as if it were loaded. Always hold the pistol in a way that does not endanger yourself or others.
- Always point the pistol in a safe direction.
- Never point the pistol at anyone, regardless of whether it is loaded or not. Even the safest pistol can become dangerous to you and others through improper handling.
- Always lay the trigger finger on the external housing. Only pull the trigger if the pistol is aimed at a safe target.
- **Never** use force when operating, inspecting, dismantling, cleaning or assembling. Improper handling impairs the function and safety of the pistol.
- Only dismantle the pistol to the extent shown in the instructions.
- Safety and function are only guaranteed as long as the pistol and bullets are in technically flawless condition.
- The pistol must be inspected by a qualified professional in case of external damage like corrosion, dropping etc.
- Always wipe away excess grease and oil and ensure that the barrel is clean and free of foreign bodies.
- Do not replace, treat, adapt or adjust any component of the pistol beyond the instructions in this manual.
- Improper adjustments impair the safety and reliability of the pistol and may lead to injury or death.
- Only allow maintenance and service work to be conducted by Carl WALTHER GmbH or a qualified repair shop.
- Never set down, carry around, transport or drop a loaded pistol.

2.3 INTENDED USE

The AP20 air pistol is a 4.5 mm caliber weapon for sport shooting at targets in shooting ranges designed and approved for the purpose.

2.4 LIABILITY AND GUARANTEE

Carl WALTHER GmbH assumes zero liability or warranty for incidents resulting from:

- Failure to observe this instruction manual.
- Non-compliance and non-observance of government regulations for handling weapons and ammunition.
- Defective handling with the weapon.
- Improper handling.
- Incorrect storage.
- Negligence.
- Use of accessories and replacement parts from other manufacturers without the express written consent of Carl WALTHER GmbH or
- Alterations, additions and conversions to the pistol without the express written consent of Carl WALTHER GmbH.

DE

EN

ES

FR

3 DESCRIPTION

3.1 CONSTRUCTION

The 4.5 mm caliber AP20 is a single shot air pistol that exclusively uses compressed air for propulsion. The removable compressed air tank is attached to the pressure reducer with a standard connection at an inclined angle (approx. 20° from the vertical) pointing down and back.

The components are shown in the following figure.

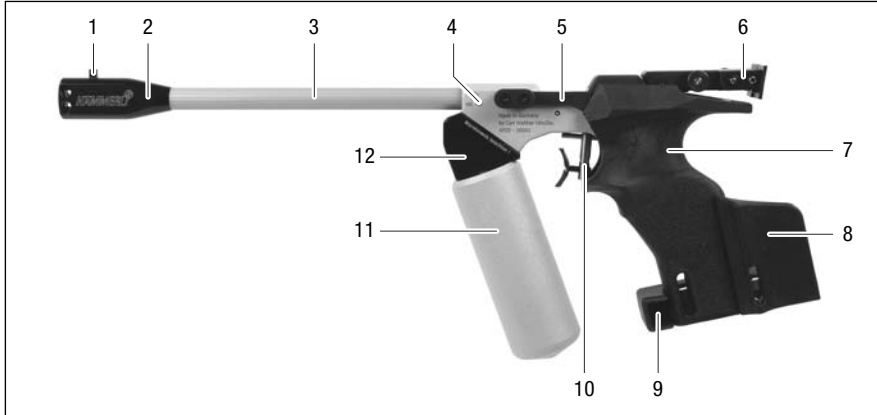

- 1 Integral front sight
- 2 Compensator
- 3 Barrel with barrel sleeve
- 4 System housing
- 5 Cocking lever
- 6 Rear sight

- 7 Grip
- 8 Palm rest
- 9 Hand rest
- 10 Trigger
- 11 Compressed air tank
- 12 Pressure reducer

3.2 COMPONENTS

3.2.1 Sights

The sight is an open design with rear sight and front sight. The notch of the rear sight is square with an individually adjusted width (see Chapter 5.3.6). The integral front sight has three widths (see Chapter 5.3.1).

3.2.2 Barrel

The barrel is made of steel and protected with a replaceable barrel sleeve (see Chapter 5.6). A variety of colors are available to suite individual preferences.

3.2.3 Trigger

The trigger is optimally calibrated ex works according to ISSF regulations. It still offers a number of versatile settings (see Chapter 5.3).

Blank shots can be fired for practice purposes (dry training) (see Chapter 5.5.7).

3.2.4 Grip

The grip is made of robust fiber-reinforced plastic and is screwed from below onto the system housing; it can be individually set to sizes S-L by adjusting the hand rest and palm rest (see Chapter 5.1.1 / 5.1.2) and is easily repositioned for left-handed shooters (see Chapter 2.1).

3.2.5 Compressed air tank

The compressed air tank is approved for max. 200 bar and is screwed onto the pressure reducer. It can be removed, filled or changed at any time (see Chapter 3.2.5).

Out of the box, the pressure reducer is mounted to the pistol so that the compressed air tank attaches externally at an inclined rearward angle. The pressure reducer may also be converted to allow the compressed air tank to attach parallel to the barrel (see Chapter 5.6).

3.3 PACKAGE CONTENTS

3.3.1 Standard equipment and included accessories:

- Pistol in plastic case
- Compressed air tank, 200 bar
- Barrel sleeves in various colors
- Pressure gauge
- Filling nozzles 200 bar
- Safety line
- Tool
- Instruction manual

NOTE

Package contents, standard equipment and accessories may vary.



3.3.2 Accessories

A wide selection of accessories are available for individual modifications (see Chapter 10).

4 HANDLING

Before use acquaint yourself with the handling and function of your new AP20 air pistol according to this instruction manual.

WARNING

When handling the pistol the hazard of unintended firing arises which can result in deadly injury.

- ▶ Never set down a loaded pistol.
 - ▶ Never carry the pistol around.
 - ▶ Never drop a loaded pistol.
-

This air pistol is a weapon and for this reason may only be used by persons who have completely read and understood this instruction manual. Its use must occur with utmost caution and in compliance with the safety instructions (Chapter 2) described in this instruction manual as well as government regulations in your country.

The pistol has optimized base settings out of the box; however, the weapon can be adapted to the individual requirements of the shooter (e. g. left-handed shooters) (see Chapter 5).

4.1 INITIAL OPERATION

The completely assembled pistol comes in a plastic case. The accompanying compressed air tank is empty and must be filled with compressed air as described in Chapter 6.2. Observe the specifications and safety instructions associated with this chapter (see Chapter 6.1).

Conduct a safety inspection after filling and attaching the compressed air tank (see Chapter 4.2).

4.2 CONDUCTING A SAFETY INSPECTION

A safety inspection must be conducted before and after shooting, after a break and in case of malfunction. The inspection serves to confirm that the pistol is not loaded. The inspection must be conducted especially when receiving the pistol from another user or in any other case of uncertainty as to whether it is loaded.

The inspection must be conducted using the safety line because the pistol cannot be unloaded by hand and does not display a loaded status.

4.2.1 Inspecting the load status using the safety line

Hold the pistol firmly in your hand, finger away from the trigger.

- Press the cocking lever all the way back to open the loading tray and leave the cocking lever in the cocked position.
- To inspect, shove the safety line into the barrel opening all the way to the loading tray until you see a bullet or the safety line.
- Remove the bullet and/or safety line.
- Subsequently, lightly move the cocking lever forward (approx. 10°) and uncock the pistol by firing in a safe direction.

- Ensure that there are no foreign objects in the barrel.
- Move the cocking lever forward until it noticeably locks. The loading tray is closed. The safety inspection is thus complete.

4.3 SHOOTING

Check the pressure in the compressed air tank (see Chapter 6.3), fill if necessary (see Chapter 6.2) and conduct a safety inspection before shooting.

4.3.1 Cocking and loading the pistol

WARNING



Firing the pistol can result in severe injury to the user and persons in the vicinity.

- ▶ Observe the safety instructions for handling weapons (Chapter 2.2.2).
- ▶ Only fire in a safe direction.

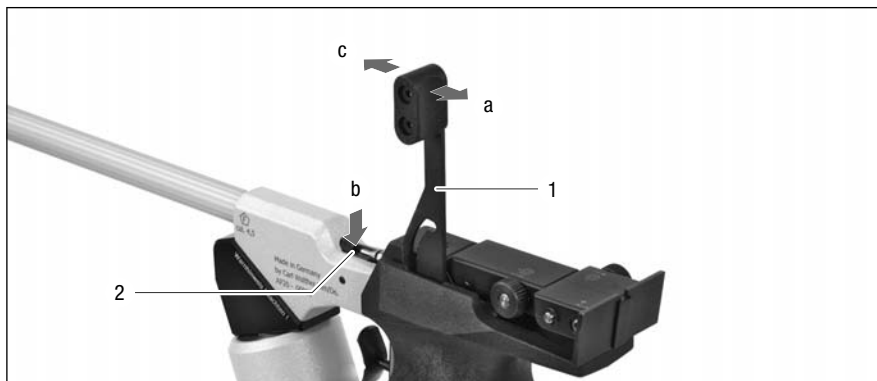

- 1 Cocking lever with grip
- 2 Loading tray

- Pull back the cocking lever (1) on the grip (a).
- Insert a bullet (Diabolo, caliber 4.5 mm) with the smooth surface forward (b) into the open loading tray (2).
- Press the cocking lever forward until it noticeably locks (c).

The pistol is cocked, loaded and ready to fire.

4.3.2 Halting shooting operations

If shooting is halted, a safety inspection does not have to take place before shooting again if the safety line has been led through the barrel to ensure the unloaded state of the pistol. The safety line must be removed before commencing with shooting.

4.3.3 Unloading the pistol

The pistol is unloaded and uncocked after the last shot. If you are uncertain of the load state, it can be inspected with the safety line (see Chapter 4.2.1).

4.3.4 Storing the pistol

The pistol must be unloaded and uncocked for storage (see Chapter 4.2.1).

Disassembly of the compressed air tank is unnecessary with frequent use of the pistol.

Unscrew the compressed air tank to preserve the seals in case of longer periods of non-use.

5 ADJUSTING THE PISTOL TO THE USER

The AP20 air pistol can be adjusted to the individual requirements and conditions of the shooter.

HAZARD

When adjusting the pistol, the hazard of unintended firing arises which can result in deadly injury.

- ▶ Ensure that the pistol is unloaded and uncocked when making adjustments.
 - ▶ Only load and cock the pistol once the settings are final.
 - ▶ Only fire the pistol in a safe area.
-

This instruction manual assumes a standard firing position, i.e. with horizontal barrel and downward pointing grip with the barrel pointing forward. Directions like “up”, “down”, “right” and “left” as well as “front” and “back” refer to the sight of a shooter holding the pistol in a standard firing position. The instructions refer to use by right-handed shooters. Left-handed shooters should adjust accordingly.

The following components can be set and adjusted:

- Grip (Chapter 5.1)
 - Hand rest
 - Palm rest
 - Right- and left-handed configuration
- Cocking lever (Chapter 5.2.3)
 - Right- and left-handed configuration
- Rear sight (Chapter 5.3)
- Pressure reducer (compressed air tank parallel to barrel) (Chapter 5.4)
- Trigger (Chapter 5.5)
- Barrel sleeve (Chapter 5.6)

Additional components for individual adaptation are listed under accessories (Chapter 10).

5.1 ADJUST GRIP

The grip is made of robust fiber-reinforced plastic and is screwed from below onto the system housing. An adjustable, three-dimensional wooden grip is available in various sizes as an accessory (see Chapter 10).

Hand rests and palm rests are mounted by the factory for right-handed shooters. They are individually adjustable (see Chapter 5.1.1 / 5.1.2) and can be easily reassembled for left-handed shooters without disassembly of the grip (see Chapter 5.2.2).

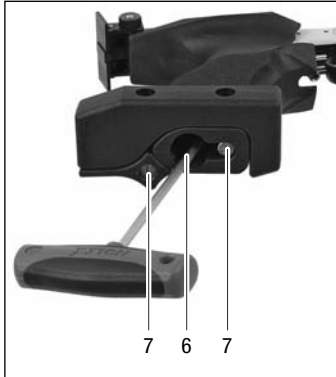

- 1 Grip
- 2 Hand rest
- 3 Fastening screw hand rest
- 4 Fastening screw palm rest



- 5 Palm rest
- 6 Fastening screw grip
- 7 Barrel pins

NOTE



First adjust the hand rest to the width of your hand when adjusting the grip. The hand should comfortably and tightly surround the grip. Personal stability settings can be adjusted by moving the palm rest.

DE

EN

ES

FR

5.1.1 Adjusting the hand rest

The grip can be incrementally adjusted between size S-L to adapt to your hand width. To do this

- Loosen the fastening screw (3) with the SW4 hexagonal key.
- Move the hand rest (2) to match the width of your hand.
- Tighten the fastening screw.

Check the settings using test targets. Repeat the adjustment process until the necessary stability settings are achieved.

5.1.2 Adjusting the palm rest

The palm rest can be incrementally moved toward the hand rest to adjust for personal stability needs. To do this

- Loosen the fastening screw (4) with the SW4 hexagonal key.
- Adjust the palm rest (5) accordingly.
- Tighten the fastening screw.

Check the settings using test targets. Repeat the adjustment process until the necessary stability settings are achieved.

5.2 RECONFIGURE THE PISTOL FOR LEFT-HANDED SHOOTERS

The pistol can be reconfigured for left-handed shooters without additional parts. The hand rest, the palm rest and, if desired, the cocking lever can be reconfigured on the grip. Dismantle the grip to convert the cocking lever.

5.2.1 Dismantling the grip

- Loosen the fastening screw (6) with the SW4 hexagonal key and unscrew.
- Pull off the grip (1), remove the barrel pins on the system housing and store with the grip.

5.2.2 Reconfiguring the hand rest and the palm rest

- Unscrew the fastening screw (4) from the palm rest (5) using the SW4 hexagonal key and remove the palm rest.
- Unscrew the fastening screw (3) from the hand rest (2) using the SW4 hexagonal key, remove the hand rest and mount on the other side of the grip using the fastening screw.
- Attach the palm rest to the grip and screw in the fastening screw (4) using the SW4 hexagonal key.

Adjust the hand rest and palm rest (see Chapter 5.1.1 / 5.1.2).

5.2.3 Reconfiguring the cocking lever

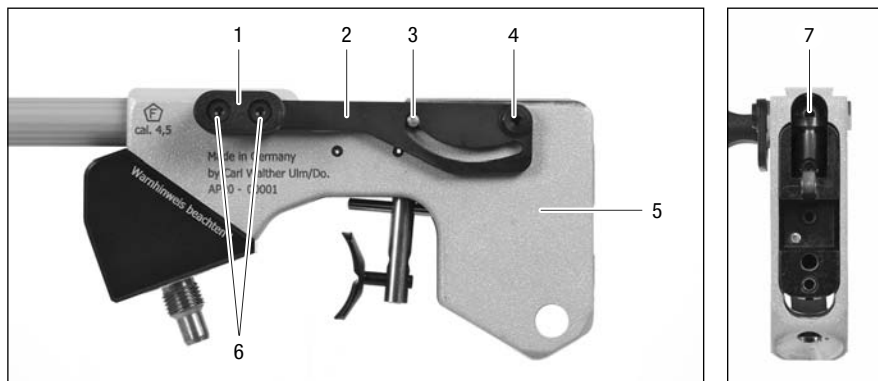

- | | | | |
|---|-------------------------------|---|------------------------------------|
| 1 | Cocking lever grip | 5 | System housing |
| 2 | Cocking lever | 6 | Fastening screw cocking lever grip |
| 3 | Guide pin | 7 | Setscrew loading pins / guide pin |
| 4 | Fastening screw cocking lever | | |

- Loosen setscrew fixation of the rear sight (2, see image page 19) with the SW2 hexagonal screwdriver and pull off the rear sight rearward.
- For a left-mounted cocking lever loosen and remove the fastening screw (4) with the hexagonal screwdriver; mind the mounted spring disk between lever and screw head.
- Remove cocking lever (2).
- Loosen and remove the fastening screw (6) on the cocking lever grip (1).
- Unscrew cocking lever grip and fasten with the screws once again to the cocking lever.
- Attach the cocking lever to the right side of the system housing (5) and fasten with the spring disk and screw.

Adjust the protrusion of the guide pin (3) to the cocking lever guide track.

- Loosen the setscrew in the loading pins with the SW2 hexagonal screwdriver over the backside of the system housing.
- Press the guide pin (3) to the right until the pin point protrudes out from the cocking lever guide track.
- Tighten the setscrew (7) in the loading pins.
- Lightly oil the guide pin in the cocking lever guide track.
- Press the rear sight onto the guide, adjust and fix with the setscrew.

5.2.4 Mounting the grip

Insert and adjust the barrel pins (the position of the slit indicates the direction of the setscrew).

- Attach the grip and screw in and tighten the fastening screw (6, see the image on page 15).

Adjust the hand rest and palm rest (see Chapter 5.1.1 / 5.1.2).

DE

EN

ES

FR

5.3 ADJUSTING THE SIGHT

Setting the sight and sight length depends on the anatomy and ability of the shooter. The ideal positions of the rear and front sights must be determined by testing and individually adjusting. The optimal width of the front sight should typically match the width of the «black in the target» when aiming.

WARNING



Adjustment of the sight poses the risk of unintended firing.

- ▶ Ensure that the pistol is unloaded and uncocked when making adjustments.

5.3.1 Adjusting the integral front sight

The integral front sight has three sight widths (4 mm, 4.5 mm, 4.9 mm) and is fastened in the compensator with a standard setscrew. The notches on the base of the front sight guarantee an exact setting.

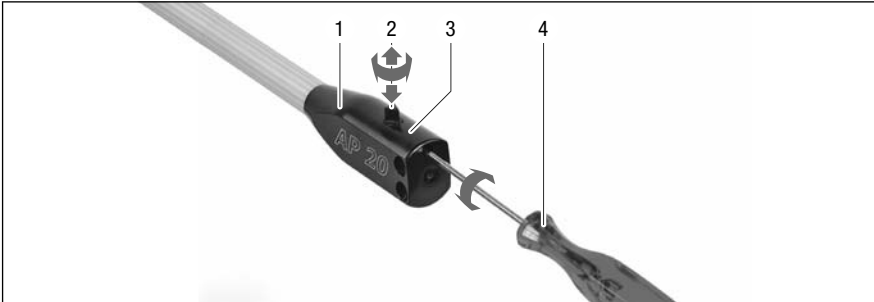

- | | |
|------------------------------------|-----------------------------|
| 1 Compensator | 3 Setscrew |
| 2 Three-stage integral front sight | 4 SW2 hexagonal screwdriver |

- Loosen the setscrew (3) on the compensator (1) using the hexagonal screwdriver (4).
- Remove the front sight (2), adjust the width of the front sight and reinsert.
- Tighten the setscrew.

5.3.2 Adjusting the rear sight

The position of the rear sight should be adjusted so that the rear sight blades are located directly over the wrist. The rear sight has a removable connection to the housing for this purpose.

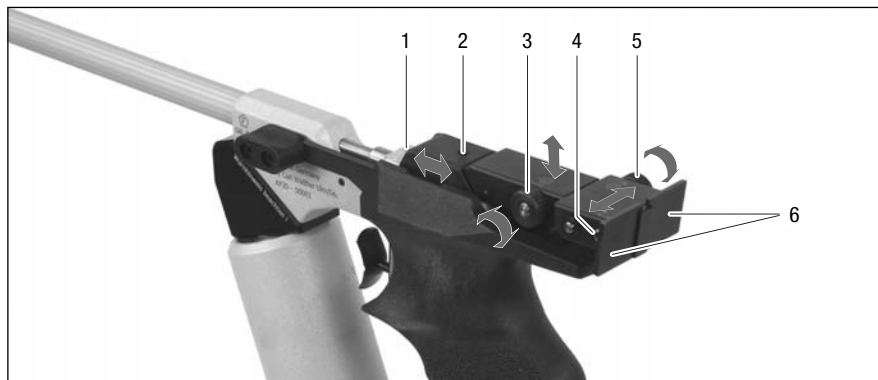

- | | |
|-----------------------------------|------------------------------------|
| 1 Guide rear sight | 4 Adjusting screw rear sight width |
| 2 Setscrew fixation rear sight | 5 Knurled screw side adjustment |
| 3 Knurled screw height adjustment | 6 Rear sight blades |

5.3.3 Rear sight fastening and relocation

CAUTION



The rear sight is mounted on a guide bar and can be shifted for the individual adjustment of the sight toward the wrist or completely removed for replacement. Shifting the rear sight by more than 15 mm impairs fastening and causes damage to the rear sight and guide.

► Shift the rear sight no more than 15 mm towards the wrist.

- Loosen the setscrew with the SW2 hexagonal screwdriver (2).
- Shift the rear sight to the desired position.
- Retighten the setscrew (2) to fix the setting.

Test the setting by shooting at a test target.

DE

EN

ES

FR

5.3.4 Adjusting the height

NOTE



At maximum sight length, every notch of the knurled screw corresponds to 1.4 mm on the target when adjusting the height and making side corrections. Approximately 8 notches represents a shift around the ring on the target.

The height adjustment of the rear sight can be altered with the knurled screw (3).

- Correction for high shot: Turn the knurled screw clockwise.
- Correction for low shot: Turn the knurled screw counter clockwise.

Test the setting by shooting at a test target.

5.3.5 Side correction

NOTE



At maximum sight length, every notch of the knurled screw corresponds to 1.4 mm on the target when adjusting the height and making side corrections. Approximately 8 notches represents a shift around the ring on the target.

The horizontal position of the rear sight can be altered with the knurled screw (5).

- Correction for shots to the right: When looking at the knurled screw, turn it clockwise.
- Correction for shots to the left: When looking at the knurled screw, turn it counter clockwise.

Test the setting by shooting at a test target.

5.3.6 Adjusting the rear sight cut-out width

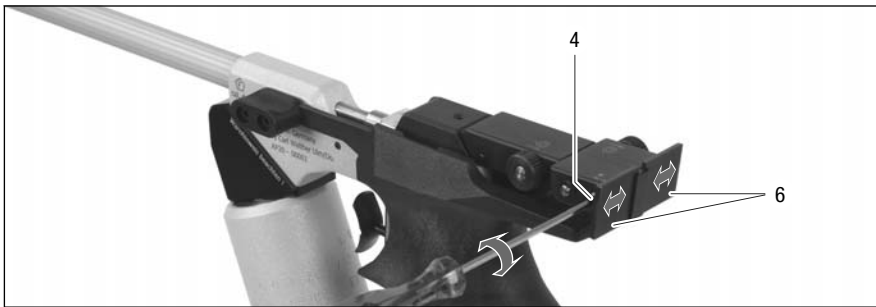

The width of the rear sight opening (4) can be altered with the screw.

- Making the rear sight opening smaller: Turn the adjusting screw clockwise using the SW2 hexagonal screwdriver.
- Widening the rear sight opening: Turn the adjusting screw counter clockwise using the SW2 hexagonal screwdriver.

Test the setting by shooting at a test target.

5.4 RECONFIGURING THE PRESSURE REDUCER

5.4.1 Empty any remaining air from the pistol's pressure reducer.

When the compressed air tank is removed from the pistol, air can only slowly escape.

- To empty the pressure reducer, cock but do not load the pistol and fire in a safe direction.
- Repeat this emptying process 2-3 times.

5.4.2 Reconfigure the pressure reducer

The pressure reducer is mounted in the downward position in the factory with connection pieces for the compressed air tank. The pressure reducer must be reconfigured for the compressed air tank to be mounted parallel to the barrel.

After configuration, a trigger guard, which is available as an accessory, can be mounted on the pressure reducer (see Chapter 10).

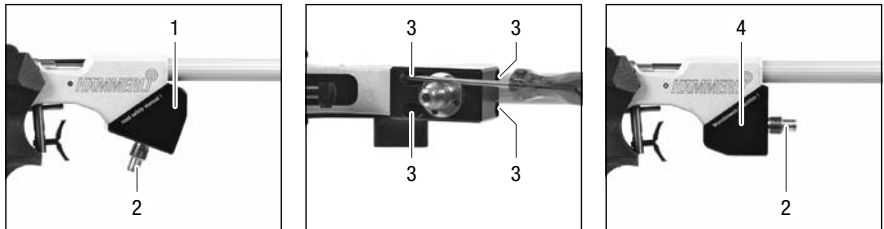

- | | |
|---|------------------------------------|
| 1 Pressure reducer (factory settings) | 3 Fastening screw |
| 2 Connection pieces (compressed air tank) | 4 Pressure reducer (user settings) |

CAUTION



An O-ring serving as a seal is fitted to the pressure reducer thus creating a compressed air connection to the system housing.

Damage to the O-rings and defilement of the mounting surfaces can lead to malfunctions.

- ▶ Inspect the O-ring for damage and replace if necessary.
- ▶ Keep the mounting surfaces clean.

- Loosen and unscrew the fastening screw (3).
- Remove the pressure reducer (1).
- Inspect the O-ring for damage and replace if necessary.
- Inspect the mounting surfaces for defilement and clean if necessary.
- Attach the pressure reducer with the connection pieces (2) pointing toward the barrel.
- Screw in and tighten the fastening screws.
- Screw the filled compressed air tank to the pressure reducer hand-tight.

DE

EN

ES

FR

Functional test:

Can the sound of escaping air be heard?

- **No noise audible:**

- Cock and load the pistol.
- Fire the pistol in a safe direction.

- **Noise audible:**

- Conduct safety inspection (see Chapter 4.2).
- Unscrew compressed air tank and empty the remaining air in the pressure reducer (see Chapter 5.4.1)
- Dismantle the pressure reducer.
- Inspect the O-ring for damage and defilement and clean or replace if necessary.
- Inspect the mounting surfaces for defilement and clean if necessary.
- Reattach the pressure reducer and conduct the functional test.

5.5 ADJUSTING THE TRIGGER

The trigger is optimally calibrated ex works according to ISSF regulations. It still offers a number of versatile settings for individual adjustment. Heed the following warnings when adjusting the trigger.

WARNING



Changes to factory trigger settings can lead to damages, malfunctions and inability to function. Furthermore, the light touch of the trigger, shaking or other handling pose the risk of unintended firing.

- ▶ Do not make changes to the trigger settings in the absence of **extensive and relevant** experience and knowledge (experts, gunsmiths, experienced shooters).
- ▶ Attach the compressed air tank.

NOTE



Setting

- the trigger carrier, carrier base, trigger travel and trigger weight can be done without dismantling the grip.

Setting

- the trigger stop, pressure point weight and pawl intersection requires dismantling of the grip (see Chapter 5.2.1).
-

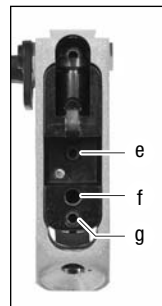
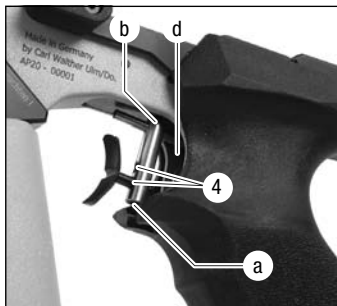
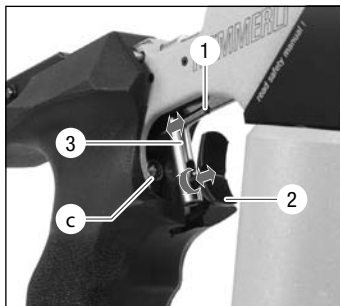

- | | |
|--|--|
| <ul style="list-style-type: none"> 1 Mounting pin for carrier base 2 Trigger carrier 3 Carrier base 4 Positioning holes trigger carrier a Setscrew trigger carrier fastening b Setscrew trigger carrier base fastening | <ul style="list-style-type: none"> c Adjusting screw trigger travel d Adjusting screw trigger weight e Adjusting screw pawl intersection f Adjusting screw trigger stop g Adjusting screw pressure point weight |
|--|--|

5.5.1 Adjusting the trigger carrier

The trigger carrier (2) setting can be horizontally and vertically adjusted to each unique trigger finger. There are two positions (4) available on the carrier base (3) for adjusting the height.

Changing the height of the trigger carrier on the carrier base:

- Loosen the setscrew (a) using the SW2 hexagonal screwdriver.
- Remove the trigger carrier from the current positioning hole and insert into the other positioning hole.
- Tighten the setscrew (a).

NOTE



If the trigger carrier was mounted onto the lower position of the carrier base, screw the setscrew (a) into the carrier base until the trigger carrier can be fastened in the upper position.

If the trigger carrier was mounted onto the upper position of the carrier base, screw the setscrew (a) out of the carrier base until the trigger carrier can be fastened in the lower position.

Twist and press the trigger carrier onto the carrier base

- Loosen the setscrew (a).
- Move the trigger carrier to the front or back or turn it along its horizontal axis to the desired position.
- Tighten the setscrew (a).

DE
EN
ES
FR

5.5.2 Adjusting the position carrier base

The trigger carrier must be removed before adjusting the carrier (see Chapter 5.5.1).

- Completely screw the setscrew (a) out of the carrier base.
- Loosen the setscrew (b) with the SW2 hexagonal screwdriver and press the carrier base on the horizontal mounting pin into the desired position and rotate the carrier base to the right or left if necessary.
- Tighten the setscrew.
- Adjusting the trigger carrier (see Chapter 5.5.1).

5.5.3 Changing the trigger travel

The slack between the resting position of the trigger carrier and the pressure point position can be regulated using the adjusting screw (c).

- Shorten the trigger travel: Turn the adjusting screw clockwise.
- Lengthen the trigger travel: Turn the adjusting screw counter clockwise.

5.5.4 Increase the trigger pull weight

The trigger pull weight is the sum of the trigger weight and pressure point weight.

In order to increase the trigger pull weight, the first stage trigger weight and / or the pressure point weight can be increased.

- Increasing the first stage trigger weight:
Screw in the setscrew (d) clockwise using the SW2 hexagonal screwdriver. The first stage trigger weight will increase.
- Increasing the pressure point weight:

WARNING



Changes to the factory settings of the pressure point weight, trigger stop and pawl intersection can lead to damages and inability of the pistol to function. Furthermore, the light touch of the trigger, shaking or other handling pose the risk of unintended firing.

- ▶ Do not make changes to the settings in the absence of **extensive and relevant** experience and knowledge (experts, gunsmiths, experienced shooters).
- ▶ Attach the compressed air tank.

Screw in the setscrew (g) clockwise using the SW2 hexagonal screwdriver. The pressure point weight will increase.

5.5.5 Adjusting the trigger stop

Observe the warnings on page 24! The trigger creep is adjusted using the trigger stop (section between shot discharge and trigger stop).

CAUTION



If the trigger creep is too tight, it can lead to irregular shots and pistol malfunctions.

- ▶ Partially unscrew the trigger stop setscrew (f) (clockwise).

- Dismantle the grip (see Chapter 5.2.1).
- Screw in the setscrew (f) clockwise. The trigger creep will shorten.

5.5.6 Adjusting the pawl intersection

The setscrew (e) is adjusted in the factory and should not be altered if possible.

Observe the warnings on page 24!

If the pawl intersection must be adjusted, observe these instructions:

Dismantle the grip (see Chapter 5.2.1). With a cocked and unloaded pistol (cocking lever and vertical position) screw the setscrew (e) in until the trigger disconnects on its own. Then turn back the setscrew by at least a 1/6 rotation.

5.5.7 Training trigger

Cock the pistol for dry training using the cocking lever. Move the cocking lever forward not more than 10°; the loading tray must remain open. Do not load the pistol. Pull the trigger.

After shooting, move the cocking lever once again into its end position, move it forward and then fire another training shot.

Upon firing the training shot, the hammer is released, yet the compressed air valve does not open and no compressed air is used.

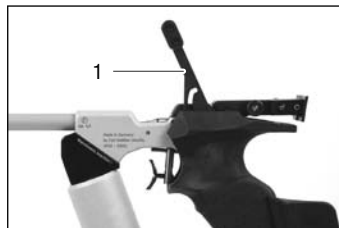

1 Cocking lever in dry training position

NOTE



In competition, if the cocking lever is closed too tight and the compressed air leaks when the training shot fires, this is evaluated as a miss with a score of zero.

5.6 CHANGING THE BARREL SLEEVE

The barrel sleeve is a changeable plastic tube that protects the exterior of the barrel from damage. A variety of colors are available to suite individual preferences.

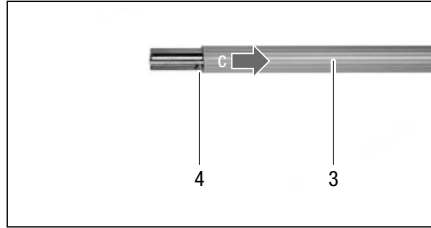
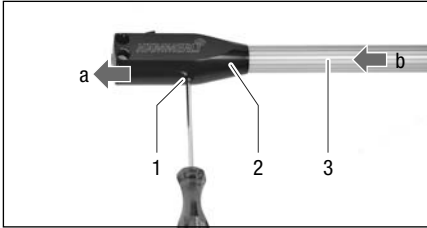

- 1 Setscrew with centering point
- 2 Compensator

- 3 Barrel sleeve
- 4 Centering mark

- Completely unscrew the setscrew (1) on the compensator (2).
- Pull the compensator forward (a).
- Pull the barrel sleeve (3) from the barrel (b).
- Press the new barrel sleeve onto the barrel up to a stop in the system housing (c).
- Press the compensator until the centering mark (4) is visible in the borehole.
- Screw the setscrew onto the compensator and tighten.

6 COMPRESSED AIR TANK

The standard compressed air tank of the AP20 air pistol is made of aluminum and approved for compressed air with **max. 200 bar**. It is screwed onto the pressure reducer and can be removed, filled or exchanged at any time (see Chapter 3.2.5).

If handled improperly, the compressed air tank can burst and severely injure people in the direct vicinity.

Always observe the safety instructions in Chapter 6.1 (assembly / dismantling, filling, emptying, storing) when handling compressed air tanks.

6.1 SAFETY INSTRUCTIONS FOR HANDLING COMPRESSED AIR TANKS

- Observe the compressed air tank's maximum duration of use of 10 years. A compressed air tank for sporting firearms may not be used for longer than 10 years.
- Empty the compressed air tank upon the expiration of the maximum duration of use (10 years from the date of manufacture) according to the instruction manual (see Chapter 6.4) and dispose of properly.
- Never exceed the maximum filling pressure. The filling pressure of the compressed air tank filling device may never be higher than the maximum filling pressure of the compressed air tank!
- Do not subject the compressed air tank to temperatures below $-20\text{ }^{\circ}\text{C}$ or over $+70\text{ }^{\circ}\text{C}$ (bursting hazard otherwise!).
- Only use the original WALTHER compressed air tank with the corresponding adapter.
- Always observe the legal regulations in your country regarding refilling.
- Do not refill leaky and/or otherwise unsafe compressed air tanks. Please empty safely.
- Only use the pressure gauge included in the package contents for testing the pressure in the compressed air tank.
- Do not use force or tools when attaching or removing the compressed air tank.
- Do not drop the compressed air tank.
- Do not label, write on, scratch, adhere stickers to or otherwise alter the compressed air tank.
- Empty and properly dispose of leaky or damaged compressed air tanks according to the instruction manual.
- Only completely emptied compressor air tanks may be transported in aircraft or sent through the mail.
- Only allow repairs to the compressed air tank to be made by the manufacturer using original replacement parts. Any liability or warranty is void otherwise.

- Do not manipulate the surface of the compressed air tank. Do not engrave or perform other abrasive procedures since this can lead to damage to the compressed air tank and, therefore, represents a safety risk.
- Inspect the compressed air tank for tears or damage before each use.
- Protect the compressed air tank against any type of force.

6.2 FILLING THE COMPRESSED AIR TANK

The removable compressed air tank is approved for a pressure of max. 200 bar. A shot capacity of approximately 120 shots can be expected from a full compressed air tank.

The compressed air tank can be removed, replaced or filled at any time with an intact and maintained device for filling the compressed air tanks.

WARNING



The compressed air tank is designed for an operating pressure of 200 bar. Filling the compressed air tank beyond 200 bar may destroy the tank and cause serious injury.

- ▶ Only fill to 200 bar using a device for filling compressed air tanks.

-
- Only attach and tighten the included adapter to the device for filling compressed air tanks.
 - Unscrew the compressed air tank from the air pistol and connect to the adapter.
 - Slowly open the valve of the device for filling compressed air tanks and close after approximately one minute.
 - Unscrew the compressed air tank from the adapter, check the pressure (see Chapter 6.3) and screw the compressed air tank onto the pistol by hand until tight.

6.3 TESTING THE PRESSURE IN THE COMPRESSED AIR TANK

Standard compressed air tanks do not have an integrated pressure gauge for displaying pressure. If the compressed air tank is inspected, for example, after filling, before shooting or after a longer period of non-use, the compressed air tank must be removed from the pistol and tested using the supplied pressure gauge.

- To check the pressure, screw the pressure gauge onto the compressed air tank and read the display.

NOTE



A small amount of pressure will escape when screwing the pressure gauge onto or off of the compressed air tank.

6.4 EMPTYING THE COMPRESSED AIR TANK

CAUTION



Higher noise levels can cause hearing damage.
The noise level of the compressed air flowing from the compressed air tanks can be extremely high.

- ▶ Always wear hearing protection when emptying compressed air tanks.
- ▶ Alert other persons to the danger and compel them to wear hearing protection.

DE

EN

ES

FR

Empty the compressed air tank with the included filling adapter.

- Unscrew the compressed air tank from the pistol.
- Slowly screw the included filling adapter onto the compressed air tank.
- The compressed air will audibly drain from the compressed air tank until completely empty.

7 MAINTENANCE

WARNING



The risk of unintended firing is possible when cleaning and maintaining the pistol.

- ▶ Ensure that the pistol is unloaded and uncocked when cleaning and maintaining.
- ▶ Attach the compressed air tank.

- The movable parts have been treated with long-lasting lubrication and must **not** be serviced by the shooter.
- Treat the metallic parts against moisture with an acid-free gun oil after use.
- After the tenth removal and re-attachment of the compressed air tank or so, lightly lubricate the thread on the connection pieces of the pressure reducer with an acid-free silicon grease.
- Lightly grease the pin in the guide track when reconfiguring the cocking lever.
- Clean the inside of the barrel using
 - commercial felt pellets for shooting through,
 - Cleaning patches for pulling through with a cleaning line.
- Always clean inside the barrel in the direction of the bullet's path, in other words, from the loading tray to the barrel.
- **Never** insert a cleaning rod into the barrel through the compensator.

8 STORAGE AND TRANSPORT

8.1 STORAGE

Observe and comply with government regulations in your country for handling weapons and ammunition. Store the unloaded pistol and accessories in the included plastic case in a dry room at room temperature.

8.2 TRANSPORT

Always transport the unloaded pistol in the included plastic case.

8.2.1 Aircraft transport

The compressed air tank must be emptied completely before transporting on an aircraft.

9 TECHNICAL DATA

Model	AP20
Caliber	4.5 mm (.177)
Trigger pull weight	500 g
Dimensions (L/W/H)	415/50/170 mm
Sight radius	360-375 mm
Width, rear sight	3-6 mm
Width, front sight	4 mm, 4.5 mm 4.9 mm
Barrel length	250 mm
Compressed air system	200 bar
Barrel sleeve	Plastic
Weight	Approx. 900 g
Standard compressed air tank shooting capacity	120 shots
Compressed air tank storage temperature	-20 °C to +70 °C

10 ACCESSORIES

Refer to the instruction manual accompanying any accessories for assembly and use.

2653842	Walther rear sight compl.
2777240	* 3D walnut grip, right, S
2777258	* 3D walnut grip, right, M
2777266	* 3D walnut grip, right, L
2784106	* 3D walnut grip, right, XL
2780909	* 3D walnut grip, left, S
2777274	* 3D walnut grip, left, M
2780917	* 3D walnut grip, left, L
2787083	3D hinge compl.
2800608	Walther Vario trigger carrier
2774631	Walther Expert trigger carrier
2776073	Slimline aluminum compressed air tank, silver, 200 bar
2780861	Slimline aluminum compressed air tank, metallic blue, 200 bar
2780879	Slimline aluminum compressed air tank, metallic red, 200 bar
2776260	Slimline Compact aluminum compressed air tank, silver, 200 bar
2799006	Trigger guard compl.
2798387	Weight bar
2798417	Weight 30 g
2798395	Weight bar with two weights each 30 g
2800900	Supporting plate

* The 3D hinge compl., article no. 2787083, is required for assembly of this grip.

DE

EN

ES

FR

Die Luftpistole **AP20** ist ein Produkt der

Carl WALTHER GmbH

Sales

P.O.Box 2740
D - 59717 Arnsberg
Donnerfeld 2
D - 59757 Arnsberg
Phone +49 (0)2932 / 63 81 00
Fax +49 (0)2932 / 63 81 49

Service

P.O.Box 4325
D - 89033 Ulm
Im Lehrer Feld 1
D - 89081 Ulm
Phone +49 (0)731 / 15 39 0
Fax +49 (0)731 / 15 39 109

Weitere Informationen zur Carl WALTHER GmbH und unseren Produkten erhalten Sie unter www.carl-walther.de oder über die vorstehenden Kontaktdaten.

RECHTLICHE HINWEISE

Trotz aller Sorgfalt können sich Daten - auch kurzfristig - ändern. Daher übernehmen wir keine Garantie oder Haftung für die Aktualität, Richtigkeit und Vollständigkeit der Informationen.

Inhalt und Gestaltung der Bedienungsanleitung sind urheberrechtlich geschützt.

Eine Vervielfältigung der Seiten oder ihres Inhaltes bedarf der vorherigen schriftlichen Zustimmung der Carl WALTHER GmbH, soweit die Vervielfältigung nicht gesetzlich gestattet ist.

© Copyrights 2012

Carl WALTHER GmbH, D - 89081 Ulm

Alle Rechte vorbehalten.

Text, Bilder und Grafiken sowie deren Anordnung in dieser Bedienungsanleitung unterliegen dem Schutz des Urheberrechts und anderer Schutzgesetze.

Der Inhalt dieser Bedienungsanleitung darf nicht zu kommerziellen Zwecken kopiert, verbreitet, verändert oder Dritten zugänglich gemacht werden.



Lesen Sie die Anweisungen und Warnungen in dieser Anleitung sorgfältig, bevor Sie diese Schusswaffe benutzen.

10 ACCESSOIRES SPÉCIAUX

Le mode d'emploi accompagnant la pièce correspondante fournit toutes les informations utiles pour le montage et l'utilisation des accessoires spéciaux.

2653842	Mire Walther complète
2777240	* Poignée 3D en noyer, droite, S
2777258	* Poignée 3D en noyer, droite, M
2777266	* Poignée 3D en noyer, droite, L
2784106	* Poignée 3D en noyer, droite, XL
2780909	* Poignée 3D en noyer, gauche, S
2777274	* Poignée 3D en noyer, gauche, M
2780917	* Poignée 3D en noyer, gauche, L
2787083	Articulation 3D complète
2800608	Queue de détente Walther Vario
2774631	Queue de détente Walther Expert
2776073	Réservoir à air comprimé Slimline en aluminium, argent, 200 bars
2780861	Réservoir à air comprimé Slimline en aluminium, bleu métallisé, 200 bars
2780879	Réservoir à air comprimé Slimline en aluminium, rouge métallisé, 200 bars
2776260	Réservoir à air comprimé Slimline Compact en aluminium, argent, 200 bars
2799006	Pontet complet
2798387	Barre de poids
2798417	Poids 30 g
2798395	Barre de poids avec deux poids de 30 g
2800900	Plaque d'appui

* Pour le montage de cette poignée de crosse, l'articulation 3D complète, n° de référence d'article 2787083 est requise.

DE

EN

ES

FR