

USER MANUAL

8001 / 8002 S2 / 9003 Premium S2 Series Models



DIE MEISTER MACHER

Issue 04/2013

Contents

1 Components / Terminology	4
2 Introduction	5
3 Key to Symbols	5
3.1 General instructions	5
3.2 Safety instructions	5
4 General handling of firearms	6
4.1 Important basics	6
4.2 Shooting	7
4.3 Maintenance	8
4.4 Transport.....	8
4.5 Storage.....	8
4.6 Hearing and eye protection	8
5 General handling of compressed air cylinders.....	8
6 Safety flag	10
7 Legal.....	11
8 Intended use	11
9 Liability.....	11
10 Before using for the first time	12
11 Soft-Link® (only Model 9003 Premium)	12
12 Removing the aluminium stock (depending on model).....	13
12.1 Removing the aluminium stock on Mod. 8002.....	13
12.2 Removing the action carrier on 9003 Precise	14
12.3 Removing the action carrier on 9003 Premium.....	14
13 Cocking, loading, engaging / releasing the safety catch	15
13.1 Cocking	15
13.2 Loading	15
13.3 Engaging the safety catch.....	16
13.4 Releasing the safety catch.....	16
14 Converting the cocking lever	17
14.1 Conversion from right to left.....	17
15 Trigger	18
15.1 Trigger weight.....	19
15.2 First stage pull (only with two-stage trigger).....	19
15.3 Sear engagement.....	19
15.4 First stage travel (only with two-stage trigger)	19
15.5 Trigger stop	20
15.6 Adjusting the trigger blade	20
15.7 Conversion from two-stage trigger to single stage trigger.....	20
15.8 Conversion from single stage trigger to two-stage trigger	20
15.9 Trigger faults caused by incorrect adjustment.....	21
15.10 Basic trigger adjustment	21

16 Dry firing device	22	22 Maintenance / cleaning	30
17 Compressed air cylinder	22	22.1 General	30
17.1 Screwing the compressed air cylinder in	23	22.2 Maintenance intervals	31
17.2 Releasing the compressed air cylinder	23	22.3 Trigger maintenance.....	32
17.3 Filling the compressed air cylinder	23	22.4 Maintenance of the optical sights	32
18 Cheek piece	24	23 Troubleshooting	32
18.1 Removing the cheek piece.....	24	24 Technical data.....	32
18.2 Adjusting the cheek piece	24	25 Disposal	33
18.2.1 Setting the cheek piece 9003 Precise	25	26 Miscellaneous	33
19 Buttplate	25	27 Shooting Performance	34
19.1 Removing the buttplate	25	28 Guarantee.....	34
19.2 Adjusting the buttplate (model-dependent)	25		
19.2.1 Buttplate adjustment 9003 Precise	26		
19.3 Buttplate adjustment options.....	26		
20 Stock adjustment	27		
20.1 Forend	27		
20.1.1 Forend raiser block adjustment 4960	27		
20.2 Grip adjustment.....	28		
20.2.1 Grip adjustment 9003 Precise	28		
20.2.2 PRO-Grip equipment (model-dependent)	29		
21 Optical sights / rear sight (option).....	29		
21.1 Mounting	29		
21.2 Elevation and windage adjustment	29		
21.3 Zero adjustment.....	29		

1 Components/Terminology



Fig. 1 Overall view using 8002 with aluminium stock as example

- | | | | |
|-----|-------------------------|------|---------------------------|
| [1] | Cheek piece | [10] | Grip |
| [2] | Rear sight | [11] | Barrelled action carrier |
| [3] | Cocking lever | [12] | Thread for weight carrier |
| [4] | Front sight | [13] | Buttplate |
| [5] | Barrel weight | [14] | Air release screw |
| [6] | Compressed air cylinder | [15] | Refilling adapter |
| [7] | Support | [16] | High sight block |
| [8] | Forend raiser block | [17] | Visible muzzle |
| [9] | Trigger | [18] | Barrel unit |

2 Introduction

Dear ANSCHÜTZ Customer,

Thank you for choosing an ANSCHÜTZ product. Many spectacular sporting successes have been achieved by marksmen, olympians and shooters in world and European championships using ANSCHÜTZ sporting rifles.

ANSCHÜTZ hunting and sporting rifles are highly reputed as a result of their well-engineered design, workmanship and outstanding shooting performance. Quality and precision are a part of our tradition, and have grown as a result of our experience since 1856.

We wish you much pleasure and sporting success with your new ANSCHÜTZ product.

Your ANSCHÜTZ team

3 Key to Symbols

In this handbook, the following symbols are used to distinguish between general information and particularly important information:

3.1 General instructions

- ▶ is the symbol for an instruction
- ✓ shows the desired result
- is the symbol for a list item
- ☞ is the symbol for a possible handling consequence

3.2 Safety instructions

⚠ identifies a safety instruction



NOTE!

An instruction indicating a specific course of action.



CAUTION!

Indicates a hazardous situation that can lead to minor physical injury or material damage.



WARNING!

Indicates a hazardous situation that can lead to serious physical injury or death.

4 General handling of firearms

Firearms are dangerous objects requiring the utmost care in their storage and use. The following safety and warning instructions must be observed without exception!



NOTE!

The firearms legislation of the relevant country must be respected and complied with.

4.1 Important basics



NOTE!

The use of firearms while under the influence of drugs, alcohol or medication is not permitted.
Vision, dexterity and judgement can all be adversely affected.
A good physical and mental constitution is a prerequisite for using a firearm.

- ⚠ *A firearm must only ever be used for its designated purpose.*
- ⚠ *Firearms owners are responsible for ensuring that their firearm is at no time, and especially when absent, within reach of or accessible to children or other unauthorised persons.*
- ⚠ *Firearms must not be handed over to unauthorised persons.*
- ⚠ *Modifications to the rifle and the use of non-genuine ANSCHÜTZ accessories can lead to malfunctions.*
- ⚠ *Serious or life-threatening injuries and damage can be caused by the use of incorrect ammunition, by contamination in the barrel or by incorrect cylinder components.*
- ⚠ *Weapons modified in a way that could affect safety must not be used. If a fault or malfunction is detected, the weapon must be unloaded and taken to an authorised gunsmith for repair.*
- ⚠ *In the event of external effects (e.g. corrosion, being dropped, etc.), the weapon must be checked by an authorised gunsmith.*
- ⚠ *A weapon must always be treated with the utmost care and be protected from accidental damage.*

4.2 Shooting

WARNING!

Danger to life and causing material damage!

Aiming the rifle at people and objects.

- When the rifle is not in use, keep the muzzle pointing in a safe direction.
- The muzzle of a firearm must never be held in a direction where it can cause damage or endanger life.



WARNING!

Malfunction when shooting!

Shot not discharged after trigger pulled.

- Do not look down into the muzzle.
- Keep the muzzle of the firearm pointing in a safe direction.
- Unload the firearm.
- Remove residues from the barrel.



- ⚠ *Any firearm must be treated as if it were loaded.*
- ⚠ *Never pick up a firearm by the trigger.*
- ⚠ *Shooting galleries must be adequately ventilated.*
- ⚠ *Any bullet trap in the shooting gallery must be completely safe and visible.*
- ⚠ *No persons may stand in the vicinity of the target during a shoot.*
- ⚠ *Firearms should not be used when visibility is poor.*
- ⚠ *Do not shoot into the air, at hard or smooth surfaces, at water or at targets on the horizon.*
- ⚠ *Do not shoot at targets if the shot could ricochet or be deflected in a dangerous manner.*
- ⚠ *To prevent accidents or damage to your rifle, never discharge a shot with the muzzle held under water or up against materials or objects.*
- ⚠ *Only shoot using the calibre specified on the barrel of the rifle.*
- ⚠ *Only new, clean, factory-charged ammunition of the calibre permitted for the rifle may be used.*
- ⚠ *The ammunition must conform to the specifications of the C.I.P.*
- ⚠ *Only ever load the rifle immediately before use.*
- ⚠ *Life-threatening injuries and material damage can be caused by the use of incorrect ammunition, contamination in the barrel or incorrect cylinder components.*
- ⚠ *Only genuine ANSCHÜTZ parts may be used.*

4.3 Maintenance

- ⚠ *Ensure that the rifle is unloaded before and after use or during maintenance and cleaning.*

4.4 Transport

- ⚠ *Firearms may only be transported in an unloaded condition and in locked containers.*
- ⚠ *When you are putting your rifle in a case or a soft case, always make sure that the rifle and the inside of the case or soft case are dry and that no water or moisture remains.*
- ⚠ *Only ever put a cleaned, dry and oiled rifle in your case or soft case.*
- ⚠ *Always place the rifle in the transport case with the sight facing upwards (towards the handle). This protects the rear sight from impacts and also protects the rear sight setting screws as a result.*

4.5 Storage

- ⚠ *Firearms that are not in use must be kept in a secure place under lock and key.*
- ⚠ *Firearms must always be stored in an unloaded and uncocked condition.*
- ⚠ *Ammunition must be kept in a separate place under lock and key.*

4.6 Hearing and eye protection



NOTE!

For your own safety, approved hearing and eye protection should be used when shooting!
Shooting without safety equipment can result in damage to your hearing and sight.

5 General handling of compressed air cylinders



NOTE!

When using compressed air cartridges please always observe the manufacturer's instructions!

- ⚠ *The fill level indicator of the compressed air cylinder may only be checked when the compressed air rifle is unloaded and uncocked.*
- ⚠ *The fill level indicator of the compressed air cylinder must not be checked during re-filling.*



NOTE!

Design aspects mean that the fill level indicator operates with an accuracy of $\pm 10\%$. Temperature influences mean that there can also be deviations in the fill level indicator.

- ⚠ *Full compressed air cylinders must not be exposed to temperatures below -20°C or above 70°C (when transporting and storing them, adequate insulation must be provided, e.g. by storing in expanded polystyrene packaging or in a gun case).*
- ⚠ *In aircraft, when sending by post, etc. the compressed air cylinders must always be unfilled.*
- ⚠ *After approx. 20 fillings, the compressed air cylinder must be emptied slowly and completely in order to allow any condensed water to escape.*
- ⚠ *When screwing on or off the compressed air cylinder or when refilling it, always stand side on in relation to the cylinder and ensure that no other person is in the vicinity of the end of the cylinder (where the manometer is positioned).*



NOTE!

ANSCHÜTZ recommends the use of an air release screw from the ANSCHÜTZ range of accessories (Item No.: 001520) for emptying the compressed air cylinder.

- ⚠ *The compressed air cylinder must be checked for cracks and damage before each use.*
- ⚠ *Compressed air cylinders which have leaks or which are damaged must be emptied safely and must not be used or filled again.*
- ⚠ *Compressed air cylinders must not be used for longer than 10 years.*
- ⚠ *After 10 years (from the date of manufacture) the compressed air cylinders must be safely emptied in accordance with the manual (see Chapter 17) and must not be used or filled any more (the date of manufacture is marked on the compressed air cylinder).*
- ⚠ *The surface of the compressed air cylinder must not be tampered with.*
- ⚠ *In particular, you must not carry out any engraving or other abrasive processes because this could lead to damage to the pressurised container and thus present a safety hazard.*
- ⚠ *Compressed air cylinders and the refilling adapter must be stored in a secure, dry, grease-free and dust-free location.*



NOTE!

The refilling adapter is also fitted with an air filter to protect from dirt and dust particles.

- ⚠ *After unscrewing the compressed air cylinder, the cylinder thread must be kept clean and the relevant protective cap must be fitted.*

NOTE!



Self monitoring!

The marksman is responsible for compliance with the regulations and stipulations contained in the ANSCHÜTZ user's handbook.

ANSCHÜTZ accepts no liability for damage of any kind caused by modification of parts, conversion or fitting of non-genuine ANSCHÜTZ parts or by non-compliance with the user's manual.

WARNING!



Danger of explosion!

Explosion danger from oiled air entry valve and thread.

- The air entry valve and thread on the compressed air cylinder should only be lightly greased using genuine ANSCHÜTZ grease (special grease 4425, Item No.: 001489).

NOTE!



Please use only genuine ANSCHÜTZ compressed air cylinders (max. 200 bar)!

If you use non-genuine ANSCHÜTZ compressed air cylinders, the liability and guarantee entitlement for the compressed air cylinder and the rifle will become void.

⚠ *The maximum filling pressure for compressed air cylinders is 200 bar at room temperature.*



WARNING!

Danger of explosion!

Overfilled compressed air cylinder.

- The maximum filling pressure of 200 bar at room temperature must not be exceeded.

⚠ *When filling the compressed air cylinder, the compressed air must not contain oil, water or any other contaminant (DIN EN 12021 - breathing air).*

⚠ *ANSCHÜTZ supplies compressed air cylinders unfilled, in accordance with the safety regulations.*

⚠ *ANSCHÜTZ recommends that compressed air cylinders be always transported empty.*

⚠ *Compressed air cylinders must never be opened or modified mechanically by non-authorized specialists.*

⚠ *The compressed air cylinder must be protected from forceful impacts.*

⚠ *Compressed air cylinders are not intended for the transport of gases of any kind.*



NOTE!

When filling, transporting and handling (including for commercial use) you must follow the "Compressed Gases Technical Regulations (TRG) or the legal stipulations applicable in the individual country concerned.

6 Safety flag



CAUTION!

Malfunction and missing action pressure!

- Bent loading mechanism caused by incorrect handling.
- Never close the action if the safety flag is inserted.

7 Legal



NOTE!

The applicable firearms legislation, regulations and provisions for the relevant country, and also the safety rules of the hunting and sporting organisations must be observed.

8 Intended use

The ANSCHÜTZ compressed air 8001, 8002 and 9003 Premium are compressed air rifles. They are exclusively for use on ranges (for sports disciplines) and must be used exclusively by persons with the relevant firearms permit.

The use is subject exclusively to the "General Technical Regulations" for all shooting sports disciplines of the INTERNATIONAL SHOOTING SPORT FEDERATION (ISSF), Bavariaring 21, 80336 München, Germany or the regulations of the INTERNATIONAL BIATHLON UNION, Peregrinstrasse 14, A-5020 Salzburg, Austria, E-Mail: biathlon@ibu.at.



NOTE!

A firearm must only ever be used for its designated purpose.

9 Liability

ANSCHÜTZ will accept no liability or claims for compensation for damage of any kind arising from:

- failure to comply with the instructions in this user's handbook,
- improper treatment or repair,
- use of non-genuine ANSCHÜTZ parts,
- incorrect handling or care,
- negligence,
- removal of the sealing lacquer,
- unauthorised tampering or
- transport damage.

CAUTION!



Modifications to or tampering with the rifle or its parts are forbidden and may possibly infringe the guarantee conditions. Alterations of this kind can have an adverse effect on the safe use of the product and lead to accidents that endanger life and limb. In such cases the guarantee is automatically void.

 *The rifle must be examined for any changes each time before use.*

10 Before using for the first time



NOTE!

For safety reasons, check the action fixing each time before you shoot.

- ▶ Wipe off any excess oil from the surface of the barrelled action.
- ▶ Cleaning cord with cotton wicks (Cleaning Kit 507, Item No.: 001491) to be pulled through the barrel from the chamber towards the muzzle.

11 Soft-Link® (Model 9003 Premium only)

The air rifle and the action carrier are connected together with the Soft-Link® connection system. This action fixing has a vibration-damping fixed mount (in the area of the action housing) and a vibration-damping free mount (on the support).

Tensions that are created as a result of different materials in air rifle actions and action carriers, and their different coefficients of thermal expansion, are thus eliminated (tension-compensating thermal expansion joint).

The integrated Soft-Link® vibration dampers also de-couple the air rifle action and the action carrier. The oscillations and vibration created in the air rifle action are effectively absorbed and cannot be felt in the aluminium stock by the marksman.

The airgun is delivered with hard Soft-Link® vibration damping. The scope of delivery includes soft Soft-Link® vibration damping.

Changing the vibration damping is carried out as follows:

- ▶ Release screws [1] on both sides.
- ▶ Release the set screws [2] on both sides (approx. 4 turns).
- ▶ Pull the support [3] off the action carrier towards the muzzle.
- ▶ Remove the action [4] from the action carrier [5].

Fixing to the barrelled action carrier:

- ▶ Insert or replace the round (hard or soft) Soft-Link® elements [C] on both sides.

Fixing to the support:

- ▶ Insert or replace the long (hard or soft) Soft-Link® elements [A] on both sides (2 in number).
- ▶ Fitting the action is carried out in reverse order.

NOTE!



When using the soft Soft-Link® elements, before fitting the screws, the flanged bushes [B] must be fitted from the outside into the Soft-Link® chamber at position [1]. Then the screws must be fitted and tightened on both sides at position [1].

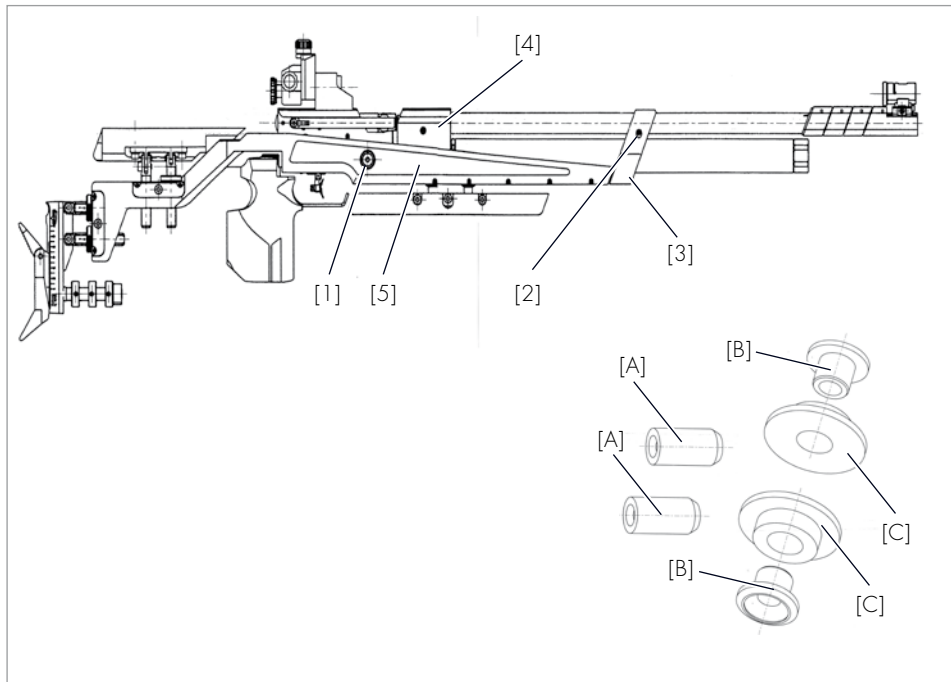

Fig. 2 Soft-Link®

12 Removing the aluminium stock (model-dependent)

12.1 Removing the aluminium stock on model 8002

- ▶ Remove the compressed air cylinder (see Chapter 17.2).
- ▶ Remove the screws [a] on the end of the support [5].
- ▶ Release the screws [b] on the support fixing.
- ▶ Remove the bedding screws [c] on the forend [6].
- ▶ Remove the forend [6].
- ▶ Remove the bedding screw [d] in the aluminium stock (in front of the trigger).
- ▶ Pull the support [5] from the aluminium stock until the mechanical connection releases.
- ▶ Remove aluminium stock from action (the vibration-absorbing elastomer in the action bed is now loose).
- ▶ Fitting is carried out in the reverse sequence.

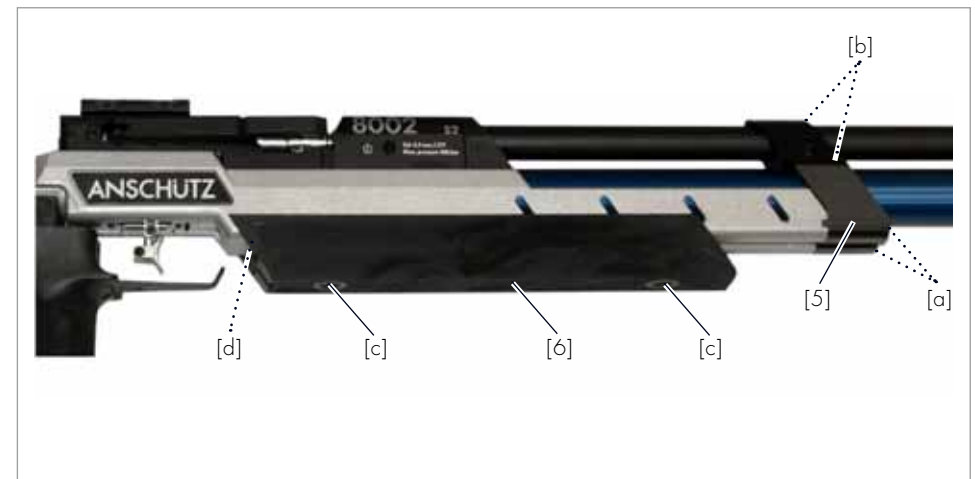

Fig. 3 Removing the aluminium stock

12.2 Removing the action carrier on Model 9003 Precise

- ▶ Remove the compressed air cylinder (see Chapter 17.2).
- ▶ Remove the screws [3a] and [3b] on the end of the support and remove the upper section of the support.
- ▶ Release the screws [1a] and [1b] at the side, then remove the action carrier.

Fitting the action carrier (for the first time)

- ▶ Place the action carrier in position on the action.
- ▶ Tighten the screws [1a] and [1b] at the side of the action carrier.
- ▶ Screw the compressed air cylinder in
- ▶ Tighten the screws [2a] and [2b], ensuring the clamping piece is not under tension.
- ▶ Tighten the screws [3a] and [3b] after fitting the support.
- ▶ Make sure that the screws are tight.

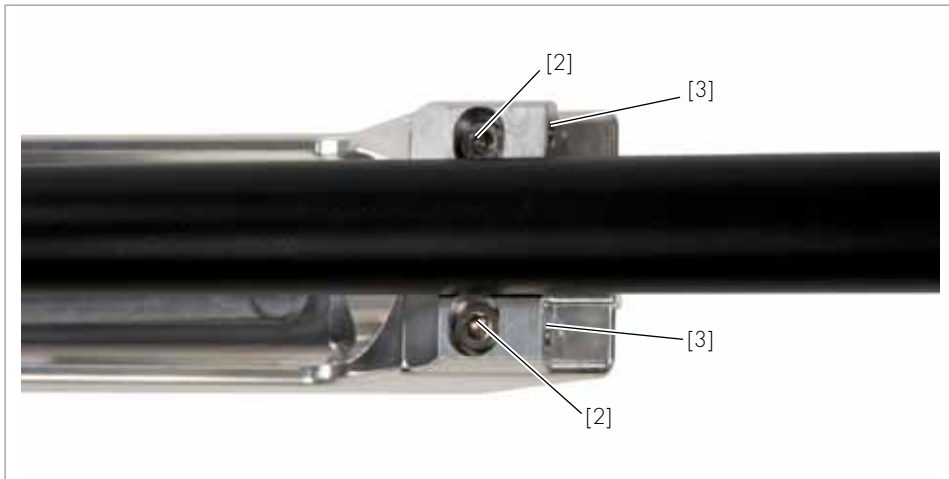

Fig. 3a Removing the action carrier

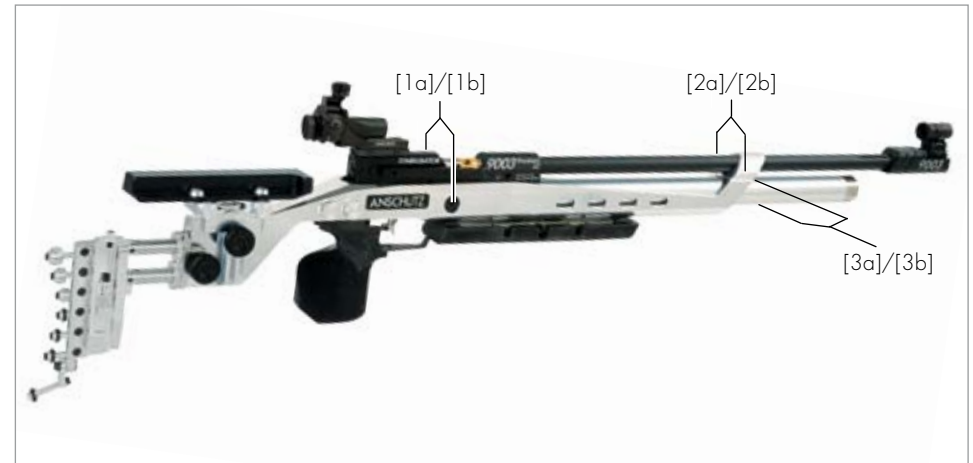

Fig. 3b Model 9003 Precise

12.3 Removing the action carrier on Model 9003 Premium

- ▶ Remove the compressed air cylinder (see Chapter 17.2).
- ▶ Release screws [1a], [1b], [2a] and [2b].
- ▶ Slide the support [3] towards the muzzle.
- ▶ Remove action carrier [5] from action [4].

Fitting the action carrier

- ▶ Fitting is carried out in the reverse sequence.

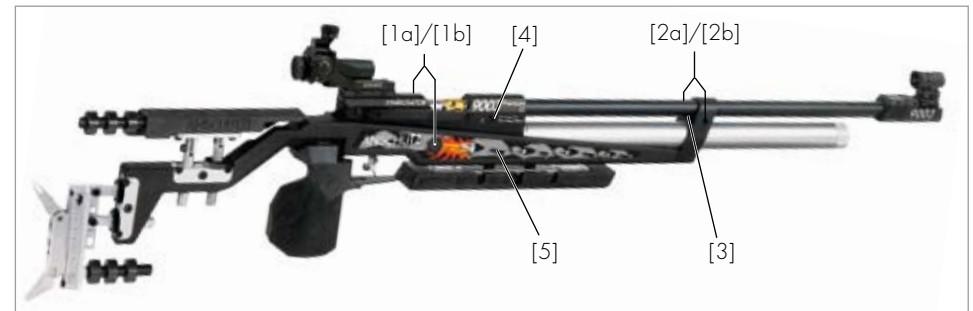

Fig. 3c Model 9003 Premium

13 Cocking, loading, setting the safety, releasing

13.1 Cocking

- ▶ To cock the cocking piston, pull the cocking lever [2] slowly (in the direction shown by the arrow) until it reaches a detectable stop.

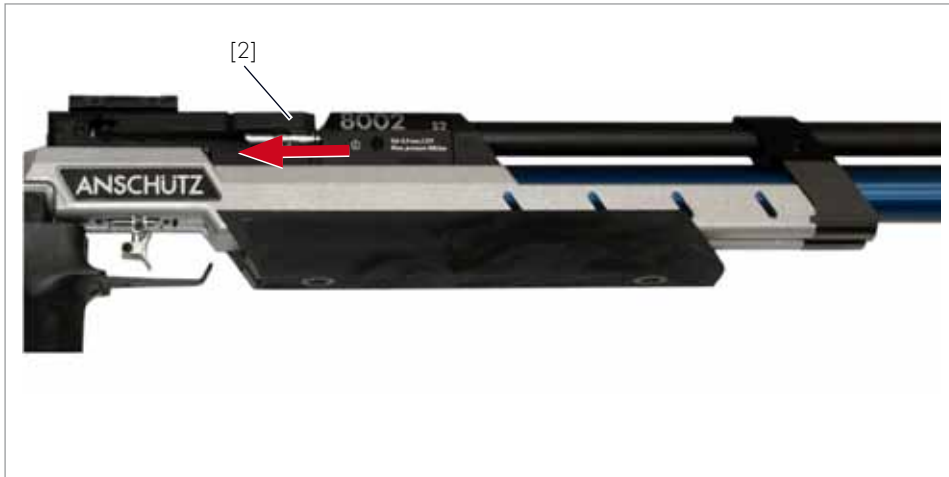

Fig. 4 Cocking the rifle

- ✓ The action opens and the opening to the barrel is revealed.

13.2 Loading

CAUTION!



Malfunction and danger of injury!

Use of non-permitted ammunition and foreign objects.

- ▶ Use only the calibre permitted for use with the firearm.

- ▶ To load, slide the lead Diabolo (with the flat end [A] facing forwards) into the chamber until it is flush.
- ▶ Lock the action by slowly closing the cocking lever [2].
- ✓ The action is locked.
- ✓ The rifle is now ready to shoot (loaded and cocked) (provided that the compressed air cylinder is full).



Fig. 5 Diabolo (shown enlarged)

- ⚠ **Unloading is carried out by shooting a pellet into the bullet trap.**

13.3 Engaging the safety catch

- ▶ Push the safety catch [x] in backwards (in the direction of the arrow, towards "S").

	NOTE!
	The safety catch must engage exactly and audibly and must not sit between the end stops. The firearm can only be engaged/released when the rifle is cocked.



Fig.6 Safety catch "Safe"

- ✓ The rifle is cocked and the safety catch is engaged.

13.4 Releasing the safety catch

- ▶ Push the safety catch [x] in forwards (in the direction of the arrow, towards "F").

	NOTE!
	The safety catch must engage exactly and audibly and must not sit between the end stops. The firearm can only be engaged/released when the rifle is cocked.



Fig.7 Safety catch "Ready to Fire"

- ✓ The rifle is cocked and the safety catch is released.



CAUTION!

Attention!

After actuating the trigger in the safe condition (dry firing), the firearm must be re-cocked to release it.

Forcible changeover of the safety can lead to damage and inadvertent discharge of a shot.

14 Converting the cocking lever

14.1 Conversion from right to left

- ▶ Remove circlip [a] from the pin [b].
- ▶ Remove pin [b].
- ▶ Release set screws [c].
- ▶ Remove the complete cocking lever assembly [d] and re-fit on the opposite side in reverse order.

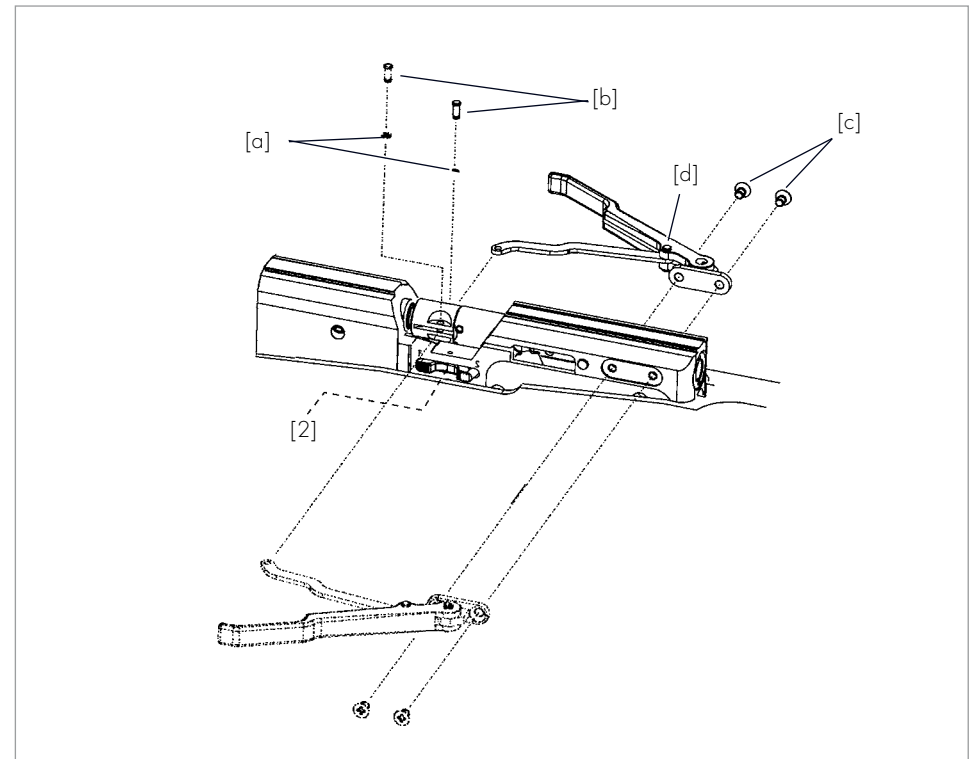

Fig. 8 Converting the cocking lever [2]

15 Trigger

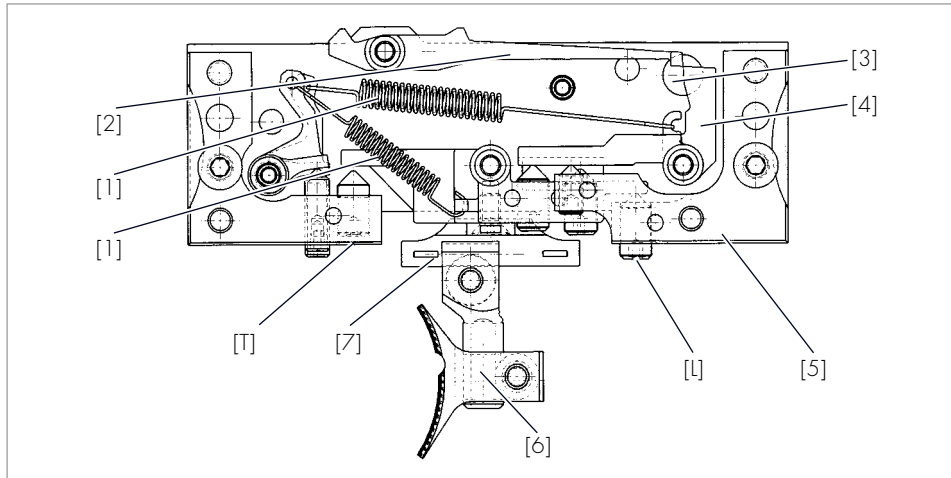

Fig. 9 Trigger (side view)

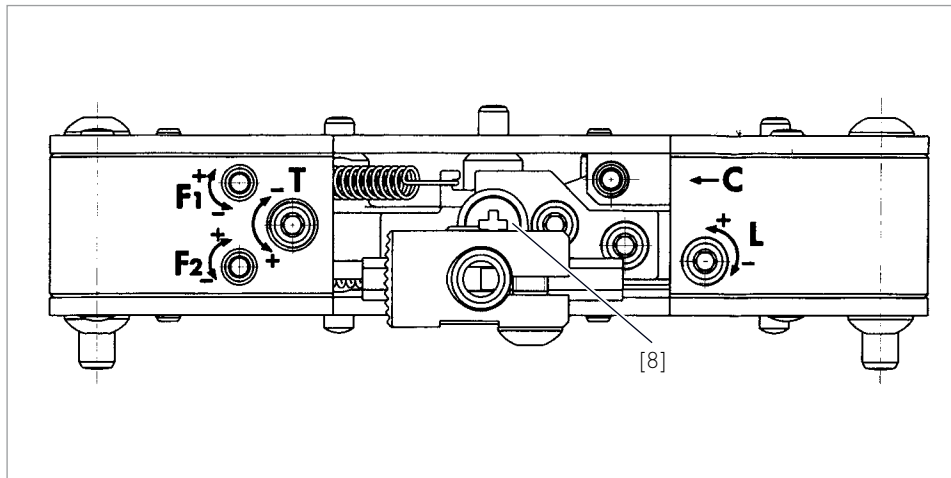

Fig. 10 Trigger (view from below)

Key (to Figs. 9+10)

- 1 Tension spring
- 2 Catch link
- 3 Viewing window
- 4 Release catch
- 5 Trigger housing
- 6 Trigger blade
- 7 Trigger sear
- 8 Trigger sear clamping screw
- F1 Weight of first stage
- F2 Trigger weight
- T Trigger stop
- L First stage travel
- C Basic factory setting/sealed



WARNING!

Danger to life!

Danger to life from loaded firearm.

- Make sure that the rifle is unloaded when carrying out alignment and adjustment procedures.



NOTE!

The trigger on Model 5065 is delivered with the following factory setting:
Two-stage trigger with approx. 100g set trigger weight.



NOTE!

The setting screws B and C are pre-set and sealed in the factory. Setting or modification using these screws is prohibited.

15.1 Trigger weight

Setting the trigger weight using the setting screw F2 (setting range from 50g to 170g):

- turn clockwise = trigger weight is increased (+)
- turn anticlockwise = trigger weight is reduced (-)

15.2 First stage pull (only with two-stage trigger)

Setting the first stage pull using the setting screw F1:

- turn clockwise = first stage weight is increased (+)
- turn anticlockwise = first stage weight is reduced (-)

15.3 Sear engagement

The sear engagement denotes the travel from the second stage to the release of the trigger. The sear engagement is set in the factory to an optimum value.



WARNING!

Danger to life!

Unintentional discharge as a result of too short a sear engagement and/or too low a trigger weight.

- Do not set the sear engagement too short.
- Do not set the trigger weight too low.
- Do not subject loaded and unsecured rifles to impact and do not use force to close the breech.

15.4 First stage travel (only with two-stage trigger)

First stage travel denotes the travel of the trigger blade from the zero position to the second stage.

Setting the first stage travel using setting screw [L]:

- turn clockwise = first stage travel is shortened
- turn anticlockwise = first stage travel is lengthened

15.5 Trigger stop

The trigger stop denotes the travel from the second stage to the end stop for the trigger blade.

Setting the trigger stop using the trigger stop setting screw [T]:

- turn clockwise = trigger stop is shortened
- turn anticlockwise = trigger stop is lengthened

	CAUTION!
	Malfunction! Trigger stop setting screw is screwed in beyond the second stage or direct function (trigger will not actuate). ➤ Trigger stop adjustment screw should not be screwed in beyond the second stage or direct function.

15.6 Adjusting the trigger blade

Release the relevant clamping screw (according to required setting). The trigger blade can be moved along the guide, swung to the side and adjusted in height.

The trigger blade can be removed completely and turned through 180°. The longer part of the trigger blade now points downwards. The blade holder is asymmetric and can be fitted offset by 180° to provide additional length adjustment. The lateral blade adjustment can also be varied in the same way. By releasing the screw (8), the trigger sear can be turned through 180° to permit offset to the side.

15.7 Conversion from two-stage trigger to single stage trigger

Adjustment using setting screw [L]. Turn the setting screw [L] to the right until there is no more first stage travel.

	WARNING!
	Danger of injury by automatic firing! Automatic firing and malfunction caused by minimum setting of trigger weight, first stage travel too small or the sear engagement is too small. ➤ Do not set the trigger weight too low. ➤ Do not set the first stage travel and sear engagement too small.

15.8 Conversion from single stage trigger to two-stage trigger

Adjustment using setting screw [L]. Turn the setting screw [L] to the left until the desired first stage travel is reached.

15.9 Trigger faults caused by incorrect adjustment

The trigger catches the cocking piston or the firing pin, but does not shoot when the trigger is actuated:

- ▶ Make sure that the safety catch is released.
- ☞ If the trigger stop setting screw [T] is screwed in too far by a few turns:
- ▶ Screw the trigger stop setting screw [T] to the left by a few turns until the cocking piston or the firing pin actuates again when the trigger is actuated.

The trigger does not catch the cocking piston or firing pin:

The setting screw [L] (first stage) is screwed in too far by a few turns.

- ▶ Screw the setting screw [L] to the left by a few turns, until the trigger catches the cocking lever or the firing pin again.
- ▶ Then set the desired first stage travel.
- ▶ Check that the tension spring [1] is undamaged and is hooked in correctly.

Setting screw [C], sear engagement, has been turned:

- ▶ Turn the setting screw [C] by approx. 1 turn to the left.
- ▶ Cock the weapon, turn the screw [C] to the right until the weapon discharges. Then turn back by $\frac{1}{5}$ of a turn.



NOTE!

The trigger function must be checked after every change. When the fault is eliminated, check the desired trigger values and reset them if necessary.

15.10 Basic adjustment of the trigger



NOTE!

This procedure is used to reset all settings on the trigger. With this starting setting, the trigger can then be individually adjusted again.

- ▶ Remove the action from the stock.
- ▶ Set the adjusting screw [T] so that the head of the screw is flush with the trigger housing surface [5].
- ▶ Set the adjusting screw [L] so that the trigger sear [7] is horizontal.
- ▶ Cock the action.
- ▶ Set the trigger using the relevant adjustment screws to give the individual settings desired.

16 Dry firing device

The safety catch can also be used as a dry firing device.

- ▶ Open the cocking lever and swing it slowly to the rear until a stop is felt.
- ▶ Push the safety catch in to "S".
- ✓ Dry firing device is active.
- ▶ Close the cocking lever.
- ▶ Release the trigger.



NOTE!

The safety/dry firing device can only be actuated when the airgun is cocked.

17 Compressed air cylinder

The compressed air rifle is fitted with an exchangeable compressed air cylinder [4]. The compressed air cylinder [4] can be exchanged in both the full and empty condition. On delivery, the compressed air cylinder [4] is not screwed in tightly. You should always use the covering cap to protect the thread on the compressed air cylinder [4] from dust and damage.



CAUTION!

Only genuine ANSCHÜTZ compressed air cylinders (max. 200 bar) may be used!



NOTE!

**Repairs to compressed air cylinders may only be carried out by the manufacturer using genuine replacement parts.
If this is not observed, the liability and guarantee become void.**

17.1 Screwing the compressed air cylinder in

- ▶ Fill the compressed air cylinder before using.
 - ▶ Screw the compressed air cylinder slowly and carefully, hand-tight, into the thread on the sub-assembly carrier (to avoid damage).
- ⚠ A perceptible resistance is felt shortly before the stop, and the valve opens automatically.**

- ▶ Screw the compressed air cylinder in, hand-tight, by approx. one more turn so that it rests tightly against the stop.

17.2 Releasing the compressed air cylinder



NOTE!

ANSCHÜTZ recommends that the compressed air cylinders always be released when the compressed air rifle is not being used to protect the housing, valve, seals, springs and for safety reasons (no readiness to fire if there is no compressed air).

- ▶ Unscrew the compressed air cylinder by approx. just one turn. Turn only so far that no air comes out.
- ▶ Cock the rifle (see Chapter 12.1) and release the trigger. Repeat the procedure 3 times (to allow any remaining air to escape).
- ☞ The compressed air cylinder can then be unscrewed with no pressure on the O-ring.



CAUTION!

Material damage!

Damage to the O-ring if the air pressure is too high.

- ▶ Never unscrew the compressed air cylinder so far that the compressed air can be heard coming out.

17.3 Filling the compressed air cylinder



WARNING!

Only refilling bottles with a maximum pressure of 200 bar may be used! Only oil- and water-free compressed air may be used (DIN EN 12021)!

Filling of the compressed air cylinders may only be carried out using the genuine ANSCHÜTZ refilling adapter (Item No.: 001521)! ANSCHÜTZ recommends the use of diving bottles for refilling the compressed air cylinders.

When screwing on or off the compressed air cylinder or when refilling it, always stand side on in relation to the cylinder and ensure that no other person is in the vicinity of the end of the cylinder (where the manometer is positioned).



NOTE!

A complete fill (max. 200 bar) is adequate for approx. 200 shots (residual pressure approx. 65 bar).*

Compressed air bottles can be obtained from firearms dealers. Refilling of compressed air bottles can also be carried out at firearms dealers or in special stores for diving equipment.

***Not applicable with Junior cylinder.**

- ▶ Check all components that are associated with the filling procedure (refilling bottle, refilling adapter, compressed air cylinder) for damage.
- ▶ Screw the refilling adapter on to the refilling bottle.

- ▶ Screw the compressed air cylinder completely on to the refilling adapter.
- ▶ Tighten the knurled screw on the refilling adapter so that no air can escape.
- ▶ Open the bottle valve very slowly until you can no longer hear a flowing noise.
- ▶ Close the refilling bottle valve again after approx. 5 seconds filling time (the compressed air cylinder will heat up slightly).
- ▶ Vent the refilling adapter by releasing the knurled screw.
- ▶ Screw the knurled screw on the refilling adapter back in.
- ▶ Unscrew the compressed air cylinder and screw it into the rifle by hand.

WARNING!

In the trade, compressed air bottles with a permissible fill pressure of 300 bar are available, and these have the same filling spigot thread as compressed air bottles having a fill pressure of 200 bar!

If you use a compressed air bottle with 300 bar to fill the 200 bar compressed air cylinder, you must use a pressure reducer set to 200 bar!

It is not permissible to fill the compressed air cylinder to over the quoted maximum pressure! The regulations and rules for filling the compressed air cylinder must be observed!



18 Cheek piece

18.1 Removing the cheek piece

- ▶ Release the clamping screw [a].
- ▶ Remove the cheek piece [1] from the holder.
- ▶ Fit in reverse order.

18.2 Adjusting the cheek piece

The cheek piece can be tilted to various positions. The knurled screws and the fixing screws [c] and [d] must be released for setting the various positions.

- ▶ Release the clamping screw [a].
- ▶ Release the setting screw [c] for the desired inclination position.
- ▶ Incline the cheek piece [1] and then retighten the setting screw [c] again hand-tight.
- ▶ The height of the cheek piece is adjusted using the knurled screw [d].
- ▶ Retighten the clamping screw [a] hand tight.

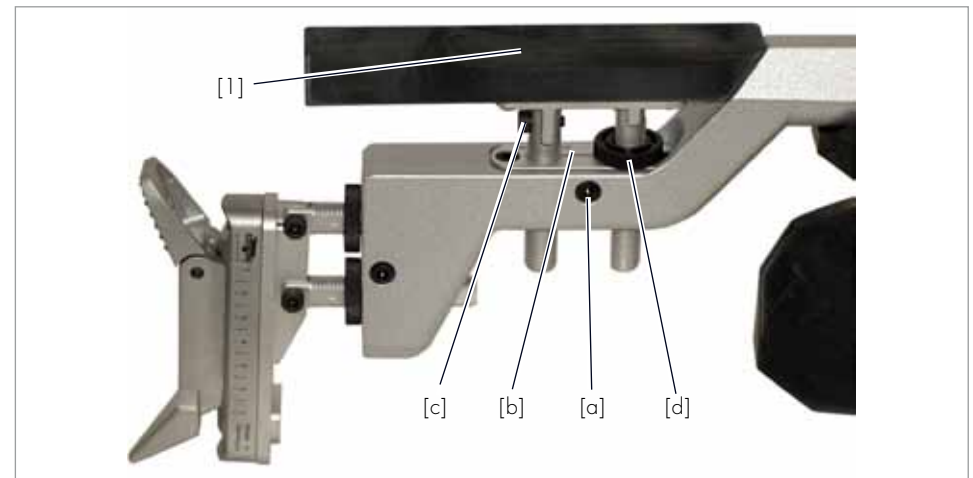

Fig. 11 Removing/adjusting the cheek piece

18.2.1 Setting the cheek piece on the 9003 Precise

- ▶ Coarse cheek piece adjustment is carried out by actuating the rotary knob [D1].
- ▶ Fine adjustment of the height of the cheek piece is carried out using the setting wheel [G1].
- ▶ Axial displacement of the cheek piece is carried out by actuating the screws [H1] and [J1]. The screws can only be released and tightened using a screwdriver.
- ▶ The horizontal angle of the cheek piece can be adjusted to suit by actuating the rotary knobs [E1] and [F1].

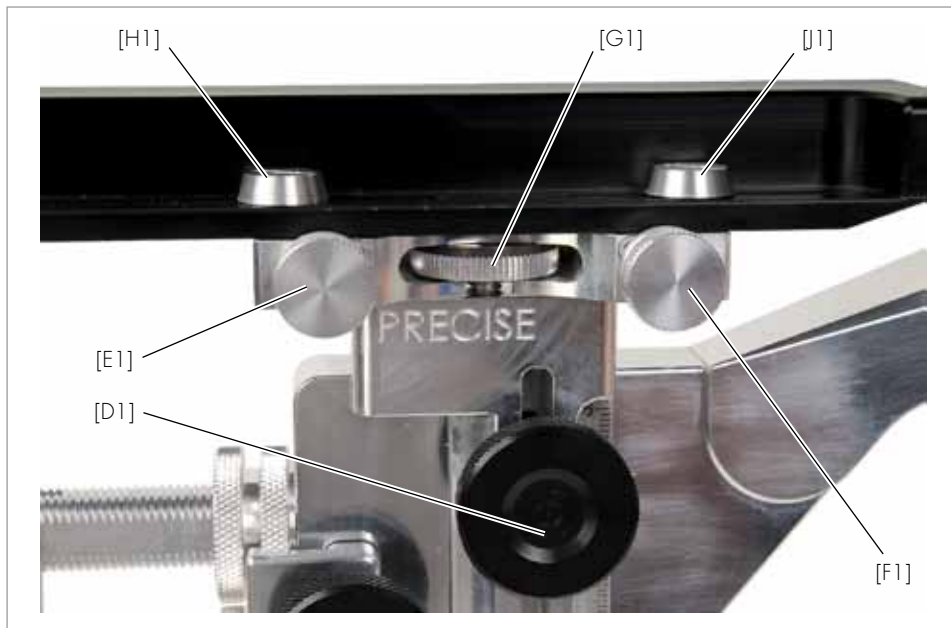

Fig. 11a Cheek piece adjustment possibilities on Model 9003 Precise

19 Buttplate

19.1 Removing the buttplate

- ▶ Release the clamping screw [a].
- ▶ Remove the buttplate [13] from the holder.
- ▶ Fit in reverse order.

19.2 Adjusting the buttplate (model-dependent)

The buttplate [13] offers various different setting options. The clamping screws must be released for setting the various different options.

- ▶ Release clamping screws [a] and [c].
- ▶ Turn the knurled nut [d] until the desired inclination and length are reached.
- ▶ Retighten the clamping screws [a] and [c] again hand-tight.

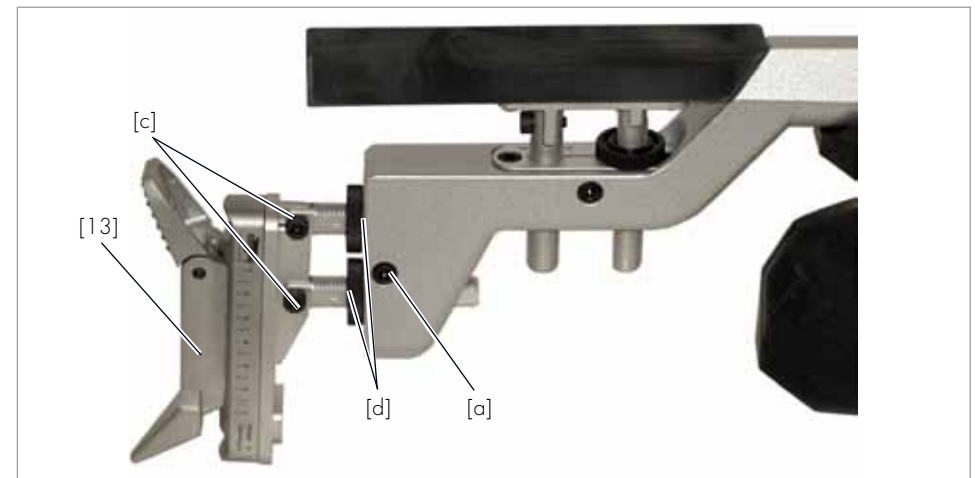

Fig. 12 Removing/adjusting the buttplate

19.2.1 Buttplate adjustment on the 9003 Precise

- ▶ For length adjustment, release the clamping screw [C1] by hand in a counter-clockwise direction until the clamping piece located underneath reveals the clamping rings [1] and [2].
- ▶ Set the clamping rings to the desired distance.
- ▶ To adjust the angle of the buttplate, release the screws [h] and [i] additionally.
- ▶ After fine adjustment, the front one of the clamping rings [1] and [2] should be enclosed by the clamping piece.
- ▶ The clamping screw [C1] should be closed by turning in the clockwise direction hand-tight.
- ▶ The screws [h] and [i] must be tightened.

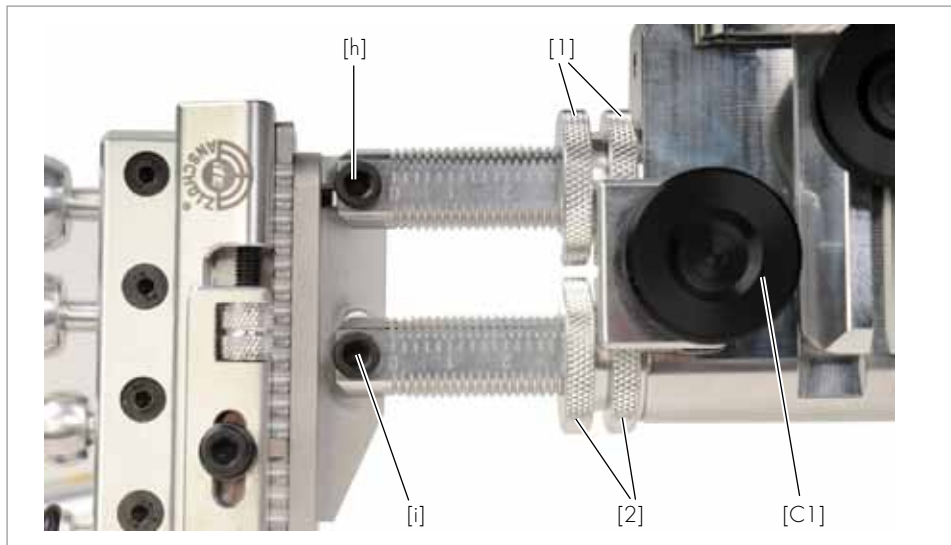

Fig. 12a Buttplate adjustment on the 9003 Precise

19.3 Buttplate adjustment options

The buttplate can be set in many different ways (depending on the model).

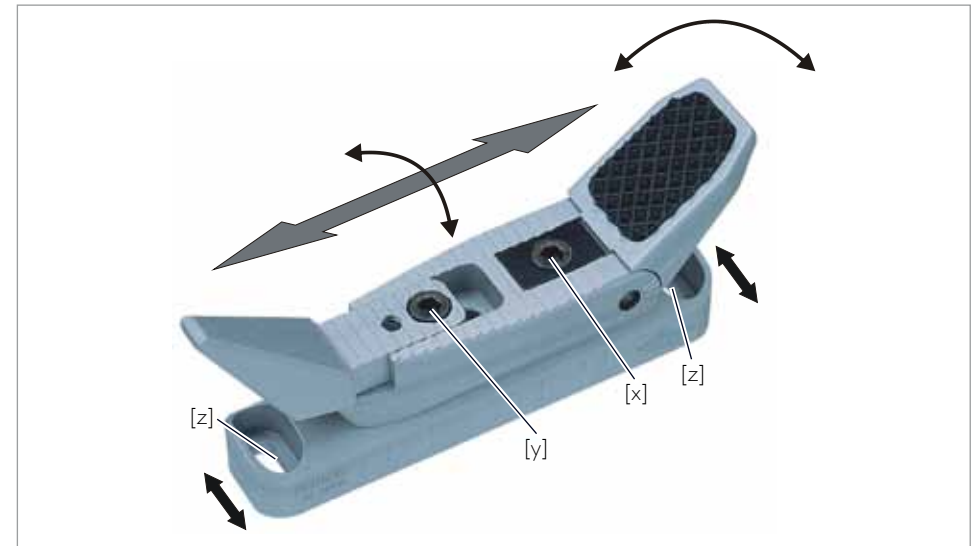

Fig. 13 Buttplate adjustment options (shown for the Type 4759 aluminium buttplate)

Key (to Fig. 13)

- [x] Clamping screw for upper plate wing
- [y] Clamping screw for height adjustment and swing movement of the buttplate
- [z] Clamping screws for lateral displacement (changing the buttplate fixing)

20 Stock adjustment

20.1 Forend

The forend [6] can be adjusted in the following areas:

- Elevation:
The forend can be adjusted in height using packing washers. Longer screws may be required.
- Length adjustment:
The forend can be moved infinitely variably on the slide rail.

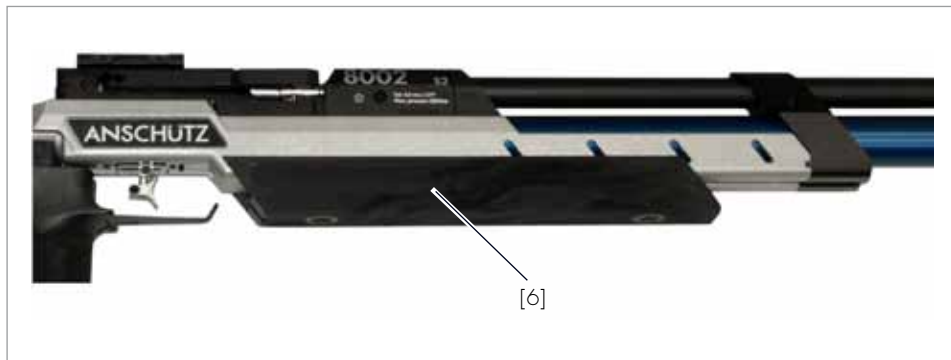

Fig. 14 Forend

20.1.1 Forend raiser block adjustment 4860

(9003 and 9003 Precise)

- ▶ Release the screws [e] and [f] for axial displacement.
- ▶ Release the screws [c] and [d] for setting the support angle.
- ▶ Release the screw [g] for elevation.
- ▶ The screws should be re-tightened after the settings have been carried out.

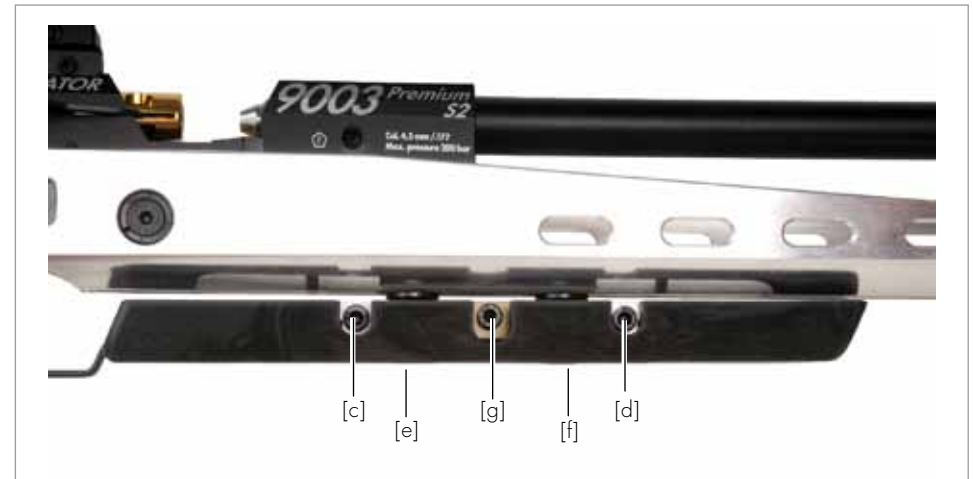

Fig. 14a Forend raiser block 9003 and 9003 Precise



Fig. 14b Forend raiser block 9003 and 9003 Precise

20.2 Grip adjustment

The rifle grip can be rotated in any direction, tilted and displaced in length by releasing the grip fixing screw [a]. Re-tighten the grip fixing screw [a] after adjusting the grip.

Re-tighten the grip fixing screw [a] slightly from time to time since settling can occur.



Fig. 15 Grip fixing screw

20.2.1 Grip adjustment on the 9003 Precise

- ▶ Release the screw [a] and [b] slightly to permit lateral grip adjustment.
- ▶ Lateral adjustment and rotation movement can be carried out by adjusting the rotary knobs [A1] and [B1].
- ▶ Re-tighten the screws [a] and [b] after adjustment.

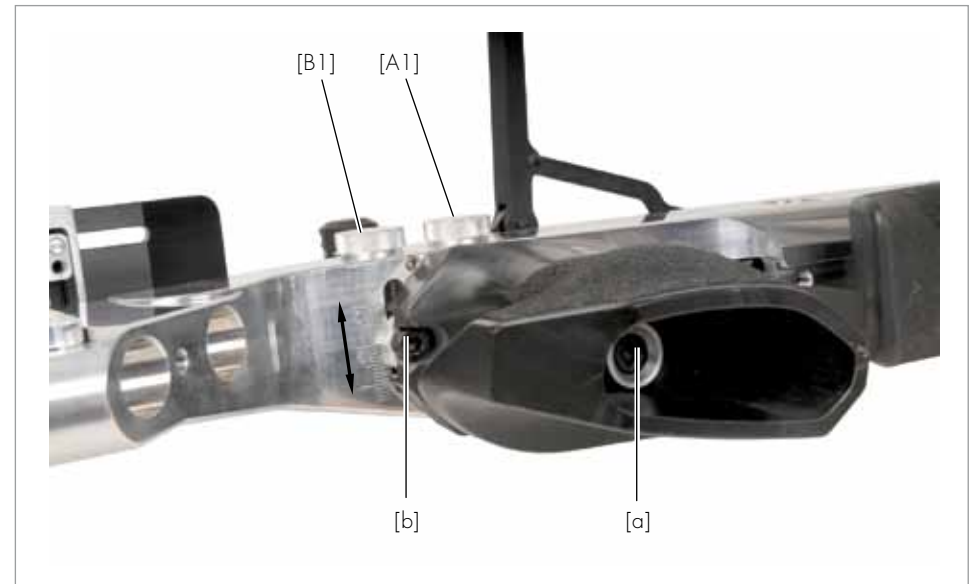

Fig. 15a Grip adjustment on the 9003 Precise

20.3 PRO-Grip equipment (model-dependent)



NOTE!

The grip, the cheek piece and the forend of the aluminium shaft are made from PRO-Grip material. These parts can be adapted to the requirements of the marksman. The PRO-Grip material can be treated as wood for this purpose. If the surface of the cheek piece is too rough, this can be smoothed down using fine glasspaper (grain size 200).

21 Optical sights/rear sight (option)

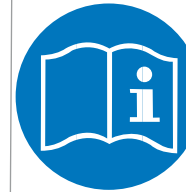

NOTE!

Operating and maintenance instructions can be found in the individual manufacturer's documentation.

21.1 Mounting

The rear sight is slid on to the 11 mm wide V-block rails and locked in a suitable position using the 2 clamping screws (just tighten hand-tight).

21.2 Elevation and windage adjustment

The elevation and windage adjusting screws have click stops. The position of the aiming point is moved from click to click.

- Elevation when shooting high = turn rotary knob in "H" direction
- Elevation when shooting low = turn rotary knob in "T" direction
- Windage when shooting to the right = turn rotary knob in "R" direction
- Windage when shooting to the left = turn rotary knob in "L" direction

21.3 Zero adjustment

After the sights have been zeroed, the two adjusting screws can be set to the "0" position.

- ▶ Release the set screws in the rotary knob.
- ▶ Position the rotary knobs to "0" on the scale.
- ▶ Tighten the set screws in the rotary knob hand-tight.
- ⚠ *The ANSCHÜTZ rear sight is aligned with zero clearance at the factory and does not require further adjustment. For this reason only the elevation and windage screws may be operated.*
- ⚠ *Do not turn the knobs beyond the stops at the end of the adjustment travel (the pre-tensioned threaded drive can be damaged).*

22 Maintenance/cleaning

22.1 General



WARNING!

Danger to life!

Danger to life from loaded firearm.

- Ensure that the rifle is unloaded before use or during maintenance and cleaning work.



CAUTION!

Injury and physical damage!

Danger of injury or physical damage as a result of not removing the oil from the barrel and chamber.

- Each time before shooting, any oil or foreign objects must be removed from the barrel and chamber.



CAUTION!

Always look out for any changes or damage that may occur to the rifle.

In the event of a change or damage, the rifle must immediately be taken to an authorised gunsmith or sent to ANSCHÜTZ for inspection.



NOTE!

The rifle should be protected from dust, sand, moisture, heat and damaging influences.



NOTE!

A dry cloth is adequate to clean the aluminium stock. Under no circumstances should you use oil.



NOTE!

To reduce the risk of breaking the stock during transport, ANSCHÜTZ recommends separating the barrelled action from the stock, especially during air travel.



NOTE!

After each use of the rifle, apply a thin film of oil to the steel parts and thoroughly clean the barrel.

When the rifle is transported from cold to warm rooms, condensation can form on the metal parts and inside the barrel. If this condensation is not quickly dried off, it can possibly lead to surface rust.

No other aids (felt plugs, non-approved grease, etc.) should be used for cleaning the barrel.

ANSCHÜTZ recommends the use of the Cleaning Kit 507 (Item No.: 001491) for cleaning



NOTE!

The rifle case / soft case should be cleaned regularly and any dust and fluff removed.

Rifle cases and soft cases should have a smooth, dust-repellent lining.

When not in use, the rifle case/soft case should always be left open to allow moisture to escape. Enclosing a desiccant can reduce the moisture content.

22.2 Maintenance intervals

Before shooting

- Carefully remove any oil from the rifle.
- ⚠ *The de-oiling of the rifle should be carried out at room temperature, as too many residues can be left in the barrel if it is very cold.*
- Fire around 10 shots to re-establish even shot performance (oil shots).

After shooting

- Allow the firearm to warm up to room temperature with the action open.
- Carefully remove condensate from the outside parts.
- Rub the firearm (steel parts) down with a suitable gun oil.

In the event of severe contamination (2000-3000 shots) or once a year in the course of inspection

- Clean the barrel with a bronze brush.
- ⚠ *Do not pull the brush backwards and forwards in the barrel.*
- Pull the cleaning wicks through the barrel in a dry condition a few times, until the final cleaning wick does not show any appreciable contamination.
- Rub the firearm (steel parts) down with an oily cloth.
- Take the rifle to a dealer/gunsmith for inspection.

22.3 Trigger maintenance

- To avoid gumming, adhesion or soiling of the trigger parts, never wash out the inner parts of the trigger with a spray or oil. Keep the trigger dry and free from dust.
- ⚠ *No dirt, solvent residues, grease or unsuitable oils must get into the trigger assembly during maintenance of the rifle. ANSCHÜTZ recommends cleaning the rifle on its side or with the stock pointing upwards, which will prevent any adverse effects on the trigger assembly.*

22.4 Maintenance of the optical sights



NOTE!

The ANSCHÜTZ rear sight is a precision unit and consequently requires the utmost care when handling.

Intensive care and maintenance guarantee perfect function.

The rear sight must be protected from dust and dirt.

23 Troubleshooting



WARNING!

In the event of malfunctions (e.g. shots not discharged, etc.) the rifle must be unloaded, secured and taken without delay to a specialist dealer/gunsmith or sent to ANSCHÜTZ.

24 Technical Data (model-dependent)

Weight	3.7 - 4.6 kg
Overall length	9003 Premium S2 Precise: 106 – 111 cm
	9003 Premium S2 Precise BENCHREST: 103 – 108 cm
	9003 Premium S2: 108 – 111 cm
	8002 S2 ALU: 107 – 110 cm
	8002 S2 BENCHREST: 105 – 108 cm
8001: 107 – 110 cm	
Barrel length	64 cm
Rifling	42 cm
Barrelled action length	78 cm
Version	Single loader
Calibre	4.5 mm
Propellant	Compressed air (200 bar max.)

25 Disposal

The disposal of the rifle must be carried out and certified by a specialist dealer or gunsmith.



26 Miscellaneous

Additional information is available on the Internet at www.anschuetz-sport.com.

News about this and other products is also provided by ANSCHÜTZ via the free-of-charge subscription to the ANSCHÜTZ Newsletter on the internet.

The original group for your rifle at 10m is affixed to the CD case.

www.anschuetz-sport.com

27 Shooting Performance

The shooting precision of a rifle depends on several factors. One very important factor in this respect is the ammunition. Not every barrel shoots with the same efficiency. Considerable performance differences are apparent with each ammunition type. The sights are just as important. As such, only ANSCHÜTZ sights should be used and the ammunition matched to your rifle. Even ammunition from the same manufacturer and the same batch can, from one production run to another, and from one rifle to another, result in varying shooting performance and hitting accuracy. When the most suitable ammunition and sights have been selected, we can guarantee the excellent shooting performance of our weapons. See warranty card.

28 Guarantee

<<< WARRANTY >>>

1. Material: This product has been released for sale after the product itself, its materials and individual components have been subjected to strict inspection, or the rifle has demonstrated its durability and function during test shooting. J.G. ANSCHÜTZ GmbH & Co. KG offers a full guarantee covering material and manufacturing faults (excluding broken stocks and springs) for a period of two years, provided that the fault can be shown to have been present at the time of handover of the product. No warranty claims will be accepted by J.G. ANSCHÜTZ GmbH & Co. KG for faults that are the result of improper use or unauthorised repairs. The item will either be repaired or replaced at our discretion. Claims for compensation - put forward for any legal reason whatsoever - are excluded.

2. Shooting Performance: The purchaser undertakes to inform J.G. ANSCHÜTZ GmbH & Co. KG in writing of any faults detected in shooting performance within one month of purchase with the submission of their own shooting record. J.G. ANSCHÜTZ GmbH & Co. KG reserves the right to transfer the rifle to an independent agency for inspection (DEVA or a national ballistics office). Should such an agency confirm excellent shooting performance, J.G. ANSCHÜTZ GmbH & Co. KG is entitled to charge the purchaser the costs of the rifle inspection. The accepted warranties do not apply to rifle damage resulting from mechanical effects and improper use or care by the purchaser. The warranty is excluded if the rifle has been repaired or modified by unauthorised persons. Likewise, the warranty is cancelled when using reloaded ammunition or ammunition which is not CIP approved.

In the event of a warranty/damage claim please enclose this card, completed and signed by your dealer, with the product.

J.G. ANSCHÜTZ GmbH & Co. KG · Jagd- und Sportwaffenfabrik
Postfach 1128 · D-89001 Ulm/Germany · www.anschuetz-sport.com



SERIAL-NO.: _____

DATE: _____

THIS ITEM WAS BOUGHT FROM: *(Stamp and signature of dealer)*